



# Using IMS Connect with OTMA / ODBM

## - Understanding the Architecture for Integration

Suzie Wendler – IBM  
IMS Support – Worldwide Systems Center (WSC)  
wendler@us.ibm.com



## Abstract



- IMS clients worldwide have a wealth of business assets in the form of IMS applications and data. The ability to facilitate open access to these assets is not only a strategic part of digital transformation, oftentimes it is a critical part of maintaining a competitive advantage. IMS has provided a set of solutions that facilitate the integration of distributed environments with your existing applications. This session explains the concepts behind IMS Connect, OTMA and TPIPEs, and ODBM. It also describes how they are set up, how they support open access to IMS, and how all these functions provide an extensive base for evolving technologies.

## Topics

- Background – IMS foundations for Integration
  - Why OTMA, IMS Connect, ODBM
- OTMA (Open Transaction Manager Access)
  - As a Server to access transactions
  - As a Client capability from IMS transactions
  - As an internal process server/broker for existing IMS transaction
  - What's New
- IMS Connect
  - As a TCP/IP gateway
    - To/From transactions
    - To IMS databases
  - What's New
- ODBM (Open DB Manager)
  - Remote Access to IMS databases

In the interest of time,  
only basic information will  
be presented

## IMS Foundation for Integration: Infrastructure Components



- OTMA (Open Transaction Manage Access)
  - Component in the IMS Control Region that supports evolving technologies
    - Opens up access to IMS transactions from environments other than VTAM
      - *Clients include IMS Connect, IBM MQ Bridge, ...*
- IMS Connect
  - Separate address space on the same or different LPAR than the target IMS system(s)
  - Functions as the IMS TCP/IP socket server
    - Opens up standardized access to IMS transactions and databases from TCP/IP clients
- ODBM (Open DataBase Manager)
  - Separate address space on the same LPAR as the target IMS system
  - With IMS Connect provides a DRDA server for JDBC access to IMS databases

Transactions

Data



# IMS Foundation for Integration to Databases - Value



## Components that enable growth for access to existing data

- Support for DRDA standards = resiliency for application developers to use relational interfaces without changing the IMS database

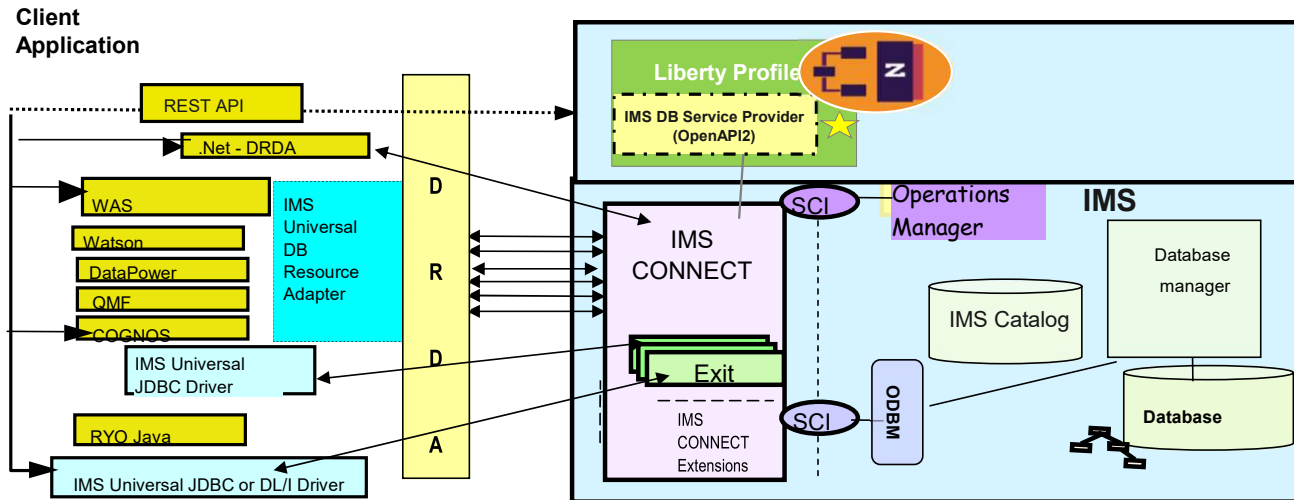

IMS Universal Drivers – provide Java applications and tools with connectivity and access to IMS databases



## Open Transaction Manager Access (OTMA)

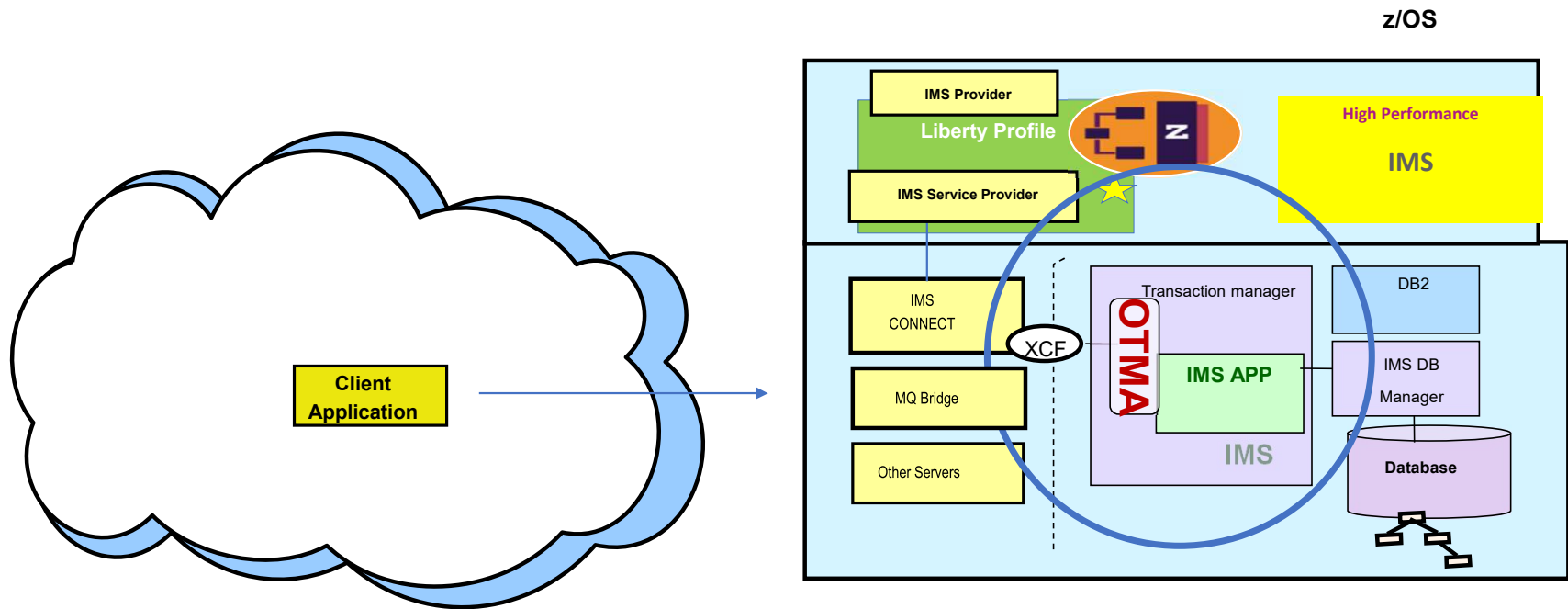

# OTMA Infrastructure



- OTMA uses cross-coupling facility (XCF) to send and receive data (messages and commands) to/from IMS from MVS applications (OTMA clients)

➤ No VTAM or TCP/IP is involved

- OTMA=Y or /STA OTMA: GRNAME=, OTMANM or APPLID



- CLIENT: MEMBER=, GROUP=, TMEMBER

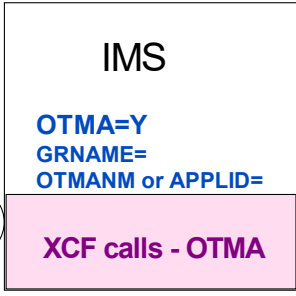
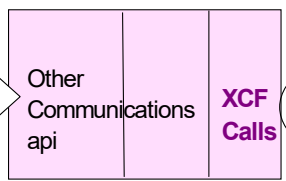
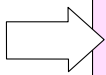
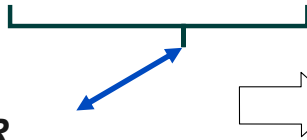

Oe.g. IMS Connect

DATASTORE ID=  
MEMBER=  
GROUP=  
TMEMBER=

- OTMA clients do not have to be in the same LPAR as IMS
- they just have to be in the same SYSPLEX



## OTMA Value Proposition – Server Support



- OTMA provides a defined communication protocol
  - OTMA clients (z/OS address spaces) can access existing IMS transactions
    - No need to modify the IMS application
- **Both IMS and the OTMA Client (e.g., IMS Connect, IBM MQ, etc.) form a group**
  - Group name is provided at initialization
- **The Client (IMS Connect) sends in a Client Bid message**
  - Must be the first message
    - Tells IMS information about the client and setup information
- **IMS validates the Client Bid**
  - Checks security
  - Prepares for processing
  - Sends an acknowledgement message to the client
- **The Client (e.g. IMS Connect on behalf of client requesters) sends in IMS transactions or commands**
  - IMS processes the request and sends the output back

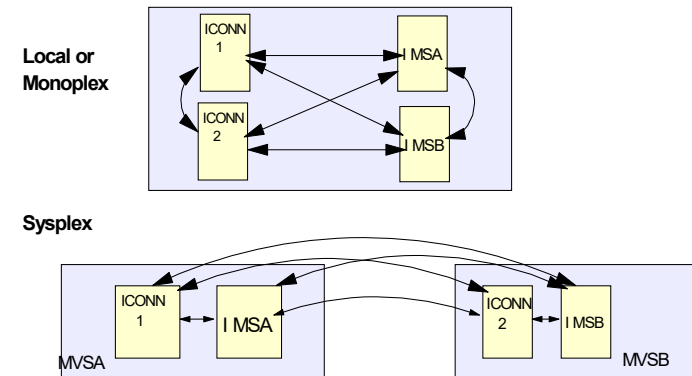

## OTMA Infrastructure

- OTMA clients run in z/OS address spaces
- *E.g. IMS Connect, IBM MQ, Clients written to use the OTMA callable interface (C/I) ...*
- *Communication to and from IMS is passed in a **prefix** in front of data and can increase queue buffer pool usage*
  - Prefix is variable in length (average of 200 to over 500 bytes with a max up to 4,096)
    - *Affects the LGMSG – SHMSG balance*

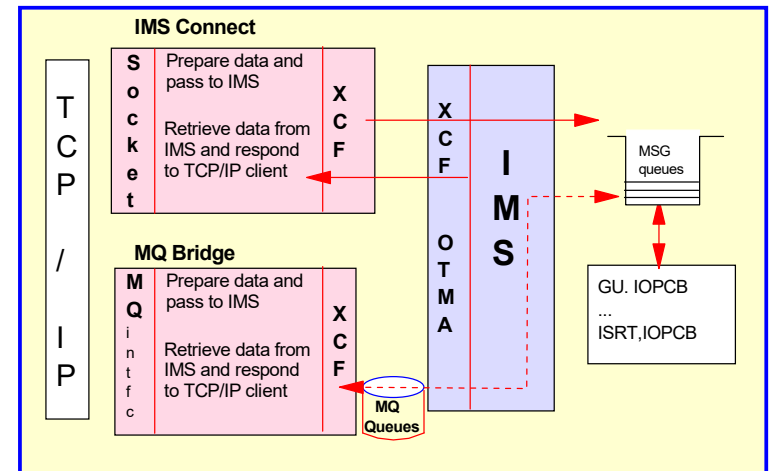

**Tip: increase size of the SHMSG/LGMSG message queue data sets and the size of the message queue pool**

# OTMA – Message Prefix



- OTMA Prefix

- 4 sections mapped by macro DFSYMSG (or HWSOMPFX for IMS Connect):
  - Control:** TPIPE name and type, message type, chaining (multi-segment), etc.
  - State Data:** Commit mode, Sync Level, IOPCB LTERM and MODNAME override, etc.
  - Security:** Security scope, Userid, RACF group, Utoken, network id, network session id
  - User:** this is client specific ( e.g., IMS Connect allows client information to be passed in)
    - > IMS Connect layout is defined in HWSOMPFX
    - > Application portion can be used to save info to pass back to the OTMA Client
- This information allows the OTMA client to communicate on a message – by – message basis, on how OTMA is to handle the request/response (logged with the 01/03 records)

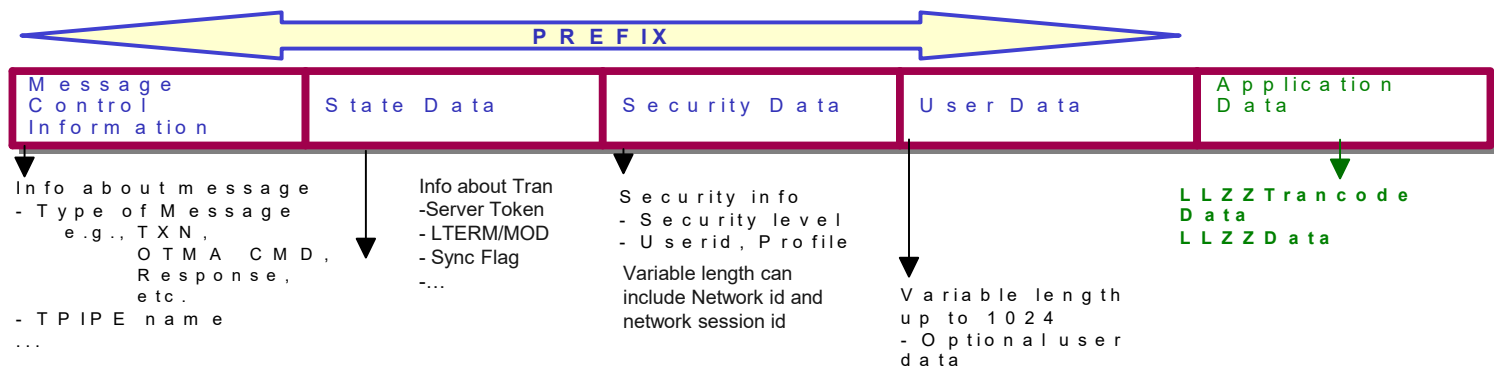

## OTMA – Commit Processing



- **Key concept : Commit Processing – Controls how IMS deals with the message**
- Synchronization Flags in the State Data section of the Prefix
  - Request control for how IMS commits transactions
- Commit Mode
  - **Commit-Then-Send (Commit Mode 0)**
    - Standard IMS flow
    - IMS processes the transaction, commits the data, sends the response
    - Messages are enqueued prior to being sent
  - **Send-Then-Commit (Commit Mode 1)**
    - IMS processes the transaction, sends the response, then commits the data
- Synchronization level
  - **Confirm** - IMS requests acknowledgment of receipt of data prior to commit (CM0, CM1)
  - **None**- IMS sends the data and immediately commits (CM1)
  - **Syncpoint (Commit Mode 2)**
    - Requires z/OS RRS (resource recovery services)

# OTMA - TPIPEs



## Transaction Pipes (TPIPEs)

### Logical connection between OTMA and its clients

- Are IMS constructs
  - Allows IMS to associate messages with a specific client
- Are not predefined
  - Different clients could use same TPIPE name (treated as unique instances)
- Are created dynamically
  - IMS Application cannot see the OTMA prefix

- For IMS applications
  - TPIPE=LTERM in the IOPCB mask
- State data prefix may provide overrides
  - LTERM, MOD

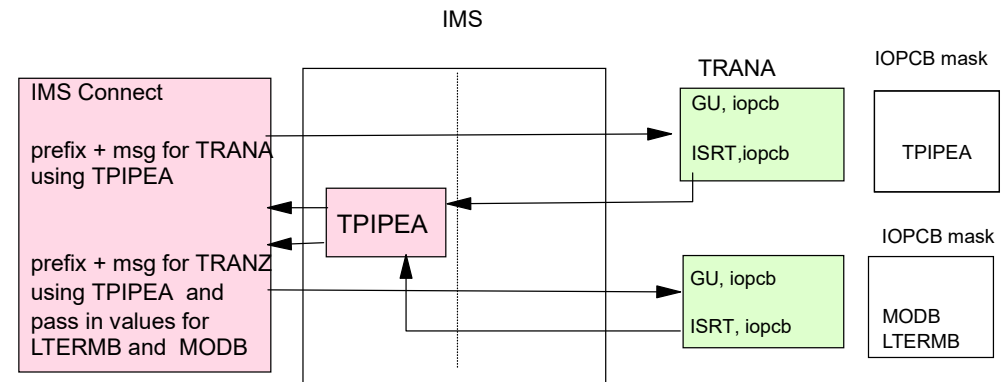
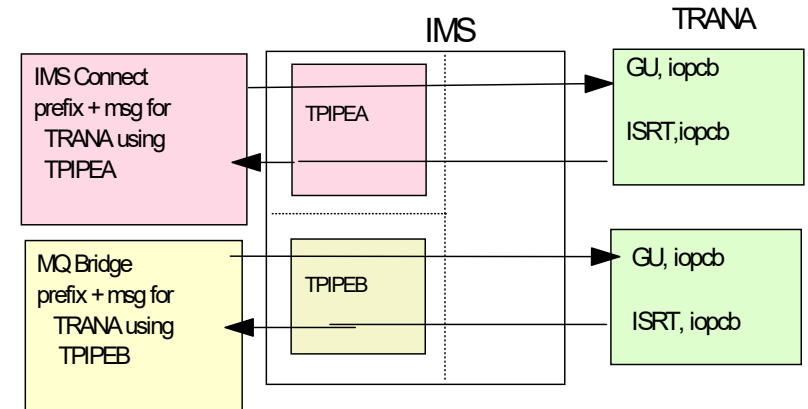

## OTMA – TPIPEs ...



- OTMA equivalent of LTERMs, i.e., logical connection between the OTMA client and OTMA
  - **Input (IOPCB) TPIPE** names are specified by the OTMA client
    - For IMS Connect for CM1 messages it is the TCP/IP Port which received the input message
      - *For IMS Connect for CM0 messages it is the IMS Connect Client Name*
        - This could lead to MANY TPIPEs!!!
    - For IBM MQ there are 2 TPIPEs per IMS Bridge Queue
      - *One for “asynchronous” messages (CM0)*
      - *One for “synchronous” messages (CM1)*
      - *The name is a 3-character user supplied prefix and a 5-digit number*
      - *It is a 2-character prefix if using MQSeries shared queues*
  - If the TPIPE does not exist, it is created
- **Asynchronous output (ALTPCB) TPIPE**
  - **Provides a one-way outbound message capability (client support) to servers/destinations outside IMS**
  - The destination in the CHNG call for modifiable ALTPCB's
    - *The destination name in static ALTPCB's*
    - *Can be overridden by the DFSYPRX0 exit or the DFSYDRU0 exit*

## OTMA – Client support (Asynchronous)



- Descriptors (DFSYDTx member of IMS.PROCLIB)
  - Mechanism to provide additional information that can affect OTMA actions
    - **Client Descriptor (defined per OTMA client instance)**  
Specifies certain characteristics for a specific OTMA client, such as exit routines, its send-then-commit message time out values, or its message flood threshold value
    - **DFSOTMA – special descriptor that defines global and default attributes**, limits, and types of support that apply to all OTMA clients
    - **Destination descriptor**  
Defines destinations for messages that are routed through OTMA

DFSYDTx member of IMS.PROCLIB

```
D destname keywords
Where: Destname is destination name
Keywords are:  TYPE={IMSCON|NONOTMA}
               TMEMBER=name
               TPIPE=name
               SMEM={NO | YES}
               ...
```

EXAMPLE

```
D OTMACL99
TYPE=IMSCON
TMEMBER=HWS1
TPIPE=HWS1TP01
```

```
M HWS1  DRU=DFSYDRU0
```

```
M DFSOTMA
INPT=50000
MAXTP=5000
MAXTPRL=60
MULTIRTP=YES
```

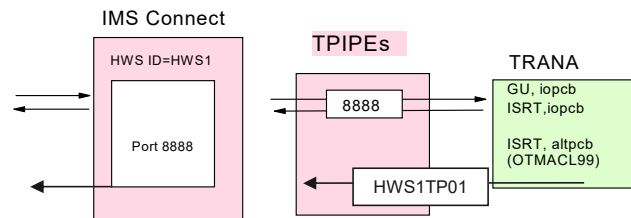

## OTMA – Client support (Synchronous)



- The DL/I ICAL (IMS callout support)
  - Provides a synchronous callout capability through OTMA (and the IMS Connect client) to resources outside IMS

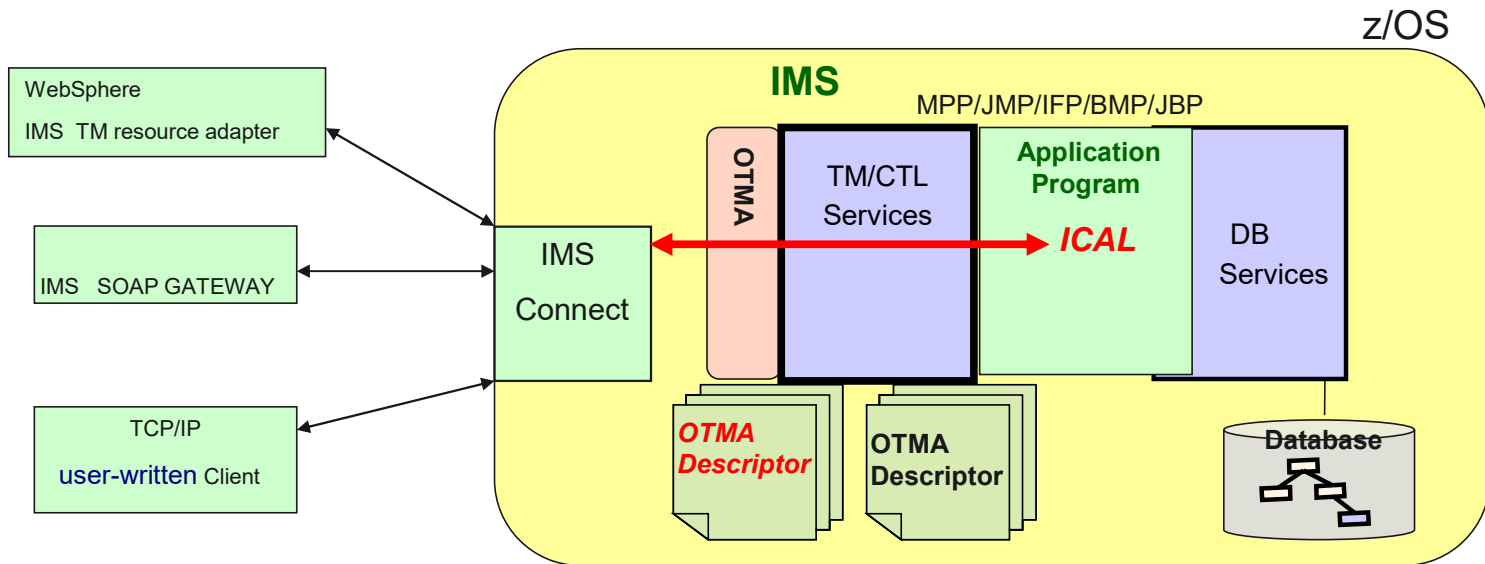

## OTMA - Internal Process Server/Broker

- **Synchronous Program Switch is an OTMA capability** that allows an IMS application program to *synchronously* call and wait for a reply from another IMS application program
  - Within the calling program's UOW

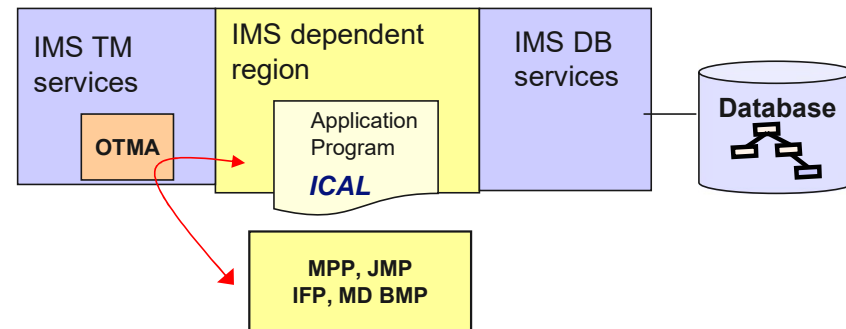

### Benefit

- Provides an internal service flow of IMS transactions to complete a business process
  - *In the same IMS or a different IMS*
- Reduces unnecessary network traffic when accessing multiple applications in the same IMS or IMSplex
- Supports the creation of a process server or broker application that can front-end existing applications to add new functionality without changing the called program

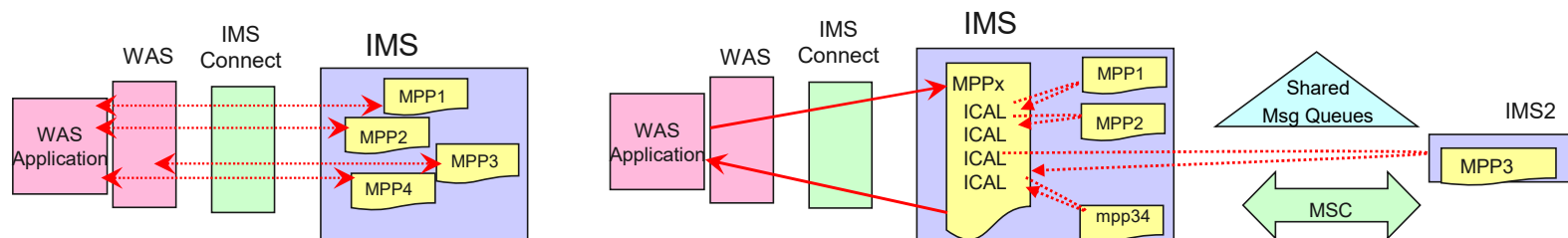

# OTMA - Transaction Orchestration



- New Function
  - Allows an IMS Connect client submitting a CMO send-recv message **to wait for and receive** an IMS asynchronous callout response from an external processing system
- Value:
  - Asynchronous callout does not hold IMS resources (dependent region, database locks) while invoking external systems

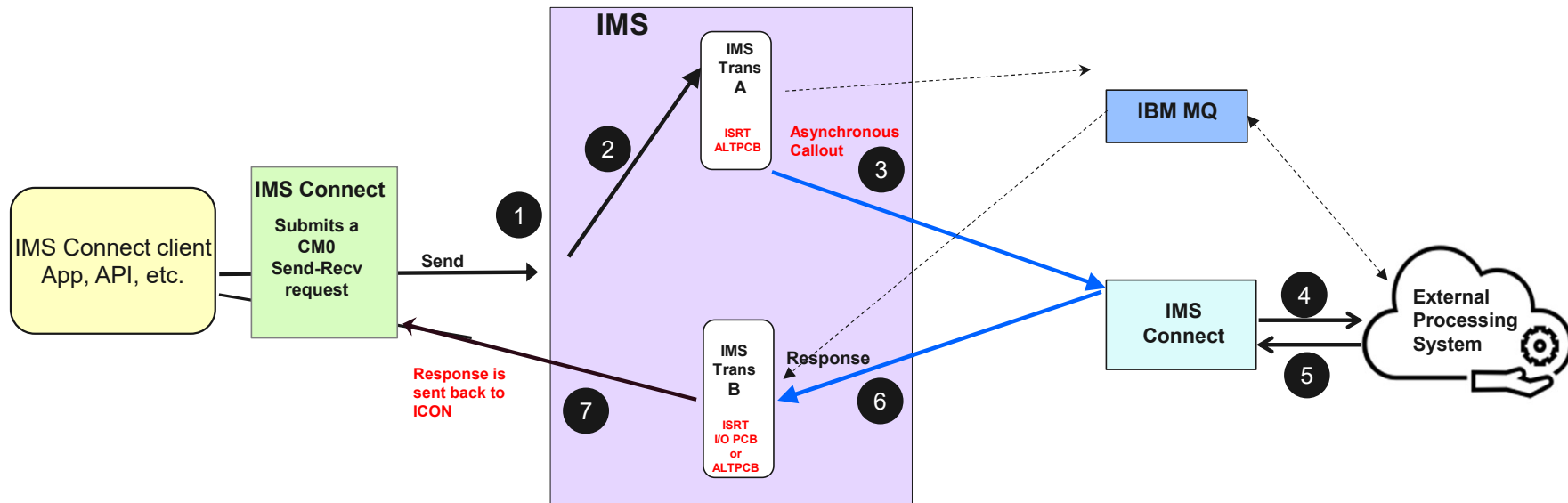



### IMS 15 OTMA Enhancements: <https://www.ibm.com/docs/en/ims/15.5.0?topic=enhancements-ims-transaction-manager>

- **PH51897/ UI96091, UI96138 and PH57295/ UI98354**
  - Transaction Orchestration new function provides a way for OTMA to identify and correctly route an external service response from IMS to a waiting IMS Connect client and support in IMS Connect with a new keyword TRANORCH
- **PH52141/UI93586**
  - A new parameter: FASTTPCU, in the DFSOTMA descriptor. When the FASTTPCU function is activated, an idle OTMA tpipe will be cleaned up after two consecutive checkpoints. (Note: by default or without this specification, an OTMA tpipe is still cleaned up after it is idle across three consecutive system checkpoints.
- **PH39434/UI83360 and PH39438/UI83364**
  - IMS ALTPCB enhancement for IMS Connect
  - New function SENDALTP allows IMS Connect clients to obtain an ALTPCB output without issuing a Resume TPIPE call.
- **PH45589/UI93202**
  - OTMA checkpoint statistics enhancement
    - Two new x'45' statistic record subtypes are added, one for Global OTMA information (x'451A') and one for OTMA Member information (x'451B'). This provides an easier way to track OTMA statistics to aid in fine-tuning the system.
- **PH17832//UI68699, UI68700**
  - OTMA lightweight transaction pipe enhancement
    - Reduction in the storage for each tpipe by dynamically allocating the associated ITASKs and other tpipe related storage only when they are needed.
- **PH02371/ UI65336**
  - Enhancement for the processing of OTMA commit-then-send messages in shared-queues environments
    - Creation of a new OTMA ITASK DFSYDAD0 to separately process OTMA commit-then-send back-end messages in a shared queues environment. As a result, the main OTMA ITASK DFSYMOM0 can focus on other important jobs. This enhancement reduces delays and improves performance. This enhancement also enhances tpipe flood control.

## OTMA – What's new – Continuous Delivery



- **PH00002/UI62030**
  - Reduction in LUMP storage for OTMA commit-then-send messages enhancement
- **PI94954/UI61211**
  - OTMA conversational transaction timeout enhancement
    - Ability to configure OTMA to end conversational transactions and remove from storage the control blocks associated with those transactions if the transaction is inactive for a specified period of time.
- **PI96089/UI57596**
  - Split of OTMA client's ACK/NAK messages to a new IMS ITASK to avoid delay for tpipe processing.
- **PI88409/UI54735, UI54736**
  - OTMA transaction pipe cleanup enhancement
    - Deletion of an OTMA TPIPE after it has been idle across three consecutive system checkpoints, even if other TPIPEs associated with the same TMEMBER are being used. Consequently, idle OTMA tpipes are made available more quickly to process subsequent transactions on the IMS message queue, and IMS storage space is less likely to become flooded.
- **PI82826/UI52624**
  - IMS ICAL processing for synchronous program switch
    - Support for the DFSMSCE0 exit for workload router processing.
- **PI81171/UI62316, UI62317**
  - OTMA ACEE flood control enhancement
    - Ability to limit the number of RACF user IDs, which in turn limits the number of ACEEs that are cached by OTMA and prevents virtual storage in the IMS control region from running out.



# IMS Connect

```
//HWS PROC RGN=0M,SOUT=A,  
// BPECFG=BPECFGHT,  
// HWSCFG=HWSCFG00  
//*  
//*****  
//* BRING UP AN IMS CONNECT USING HWSHWS00 *  
//*****  
//STEP1 EXEC PGM=HWSHWS00,REGION=&RGN,TIME=1440,  
// PARM='BPECFG=&BPECFG,HWSCFG=&HWSCFG'  
//STEPLIB DD DSN=SDFSRESL,DISP=SHR  
// DD DSN=CEE.SCEERUN,UNIT=SYSDA,DISP=SHR  
// DD DSN=SYS1.CSSLIB,UNIT=SYSDA,DISP=SHR  
// DD DSN=GSK.SGSKLOAD,UNIT=SYSDA,DISP=SHR  
//PROCLIB DD DSN=USER.PROCLIB,DISP=SHR  
//SYSPRINT DD SYSOUT=&SOUT  
//SYSUDUMP DD SYSOUT=&SOUT  
//HWSRCORD DD DSN=HWSRCRD,DISP=SHR
```

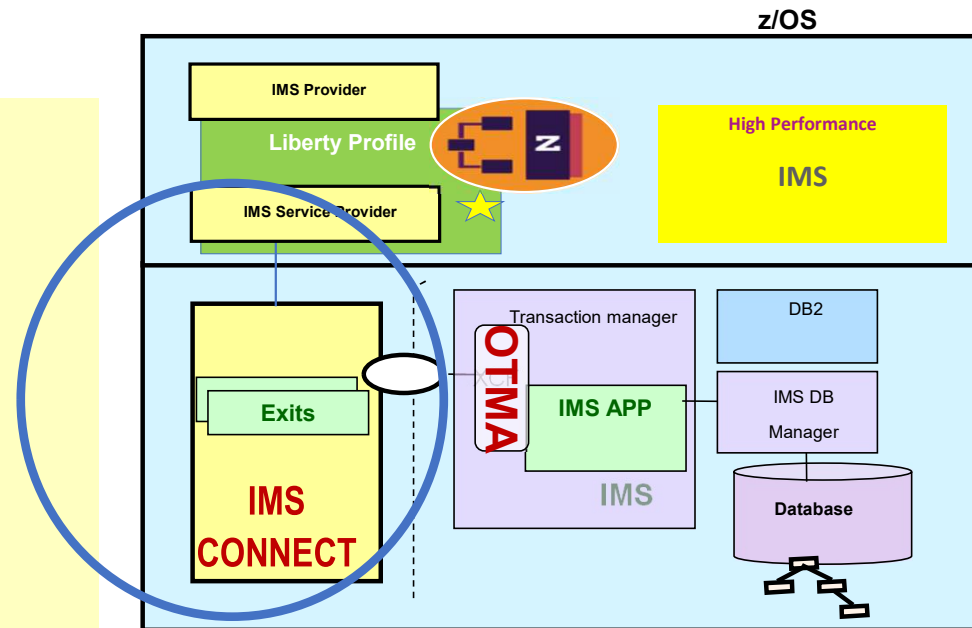

## IMS Connect – Value Proposition



- ★ **IMS Connect is a TCP/IP Server which supports TCP/IP communications between:**
  - IMS - CICS for ISC sessions (ISC/TCPIP)
  - IMS - IMS for MSC sessions (MSC/TCPIP)
  - IMS - IMS for asynchronous program-program switches (IMS-IMS/TCPIP)
  
- ★ **For Transactions, IMS Connect is an Open Transaction Manager Access (OTMA) client**
  - IMS Connect and OTMA can be on the same or different LPARs
  - IMS Connect accepts input messages from and sends output messages to clients
    - Could be any TCP/IP Socket application - IMS Connect publishes its application protocol
    - Could be a Java Application, Bean, Applet, or Servlet
    - Supports the REST API interface through z/OS Connect
  
- ★ **For Commands, IMS Connect provides Type-2 command supports**
  - Interfaces with Operations Manager (OM) via the Structured Call Interface (SCI)
  
- ★ **For Databases, IMS Connect with Open Database Manager (ODBM) is a DRDA server**
  - Supports Open Database access from the IMS universal Drivers

## IMS Connect - Basics

- IMS Connect is delivered with IMS and run as a z/OS Started Task or Job

- Controlled by two input files:

- BPECFG – Base Primitive Environment

Provides common services such as dispatching, waiting and tracing

- HWSCFG – Provides environmental definitions for IMS Connect communication and functionality

HWS  
TCPIP  
IMSPLEX

Defines global environment parameters for IMS Connect  
Provides TCP/IP connectivity parameters  
Registers IMS Connect as part of the IMSPLEX/CSL

DATASTORE  
ADAPTER  
ISC  
RMTCICS  
MSC  
RMTIMSCON

Defines connection to IMS OTMA (datastore)  
Defines characteristics of Adapters for XML conversion  
Defines ISC links  
to CICS over TCP/IP  
Defines MSC links between IMS systems over TCP/IP  
Defines a TCP/IP connection to a remote IMS Connect  
- Support asynchronous pgm-pgm switching

ODACCESS

Defines connection attributes for IMS DB (with ODBM)

```
HWS (ID=IMSDCON,XIBAREA=100,RACF=N,RRS=Y)
*
TCPIP (HOSTNAME=TCPIP,PORTID=(7000),RACFID=SYSSTC,TIMEOUT=0,
      MAXSOC=100,NODELAY=Y,
      EXIT=(HWSSMPL1,HWSCSLO0,HWSCSLO1,HWSSOAP1))
*
IMSPLEX (MEMBER=IMSDCON,TMEMBER=DEMODO)
*
DATASTORE (ID=IMSD,GROUP=IMSGROUP,MEMBER=IMSDCON,
          TMEMBER=IMSD)
*
ODACCESS (ODBMAUTOCONN=Y,
          DRDAPORT=(ID=7001,KEEPAV=200,PORTTMOT=12000),ODBMTMOT=6003)
```



## IMS Connect Basics --- For TCP/IP Support

- **A TCP/IP server (IMS Connect) specifies two things when connecting to TCP/IP**
  - A TCP/IP “stack” (instance) that provides the TCP/IP support
  - A Port on which it listening
    - A message arriving in TCP/IP for that Port will be sent to that server
    - A TCP/IP server can listen on multiple Ports (**IMS Connect supports up to 200 ports**)
  - *Server passes the message on a listening port to a socket which will be used for the message interaction so it can continue listening for new requests on the port (IMS Connect MAXSOC value supports up to 65,535 sockets) which must be coordinated with the MAXFILEPROC specification for TCP/IP*
    - Multiple TCP/IP servers (IMS Connects) can listen on the same Port
- **A TCP/IP Client connects to a server (IMS Connect) by specifying two things**
  - Target Address, e.g., for IMS Connect (myserver@tcpip.server.co)
    - Socket address – 123.456.789 or Hostname - myserver
    - Domain Name – tcpip.server.com
  - Target Port
    - The Port number that the TCP/IP server is listening on

# IMS Connect and OTMA for Transaction Access



- IMS Connect -- an OTMA client

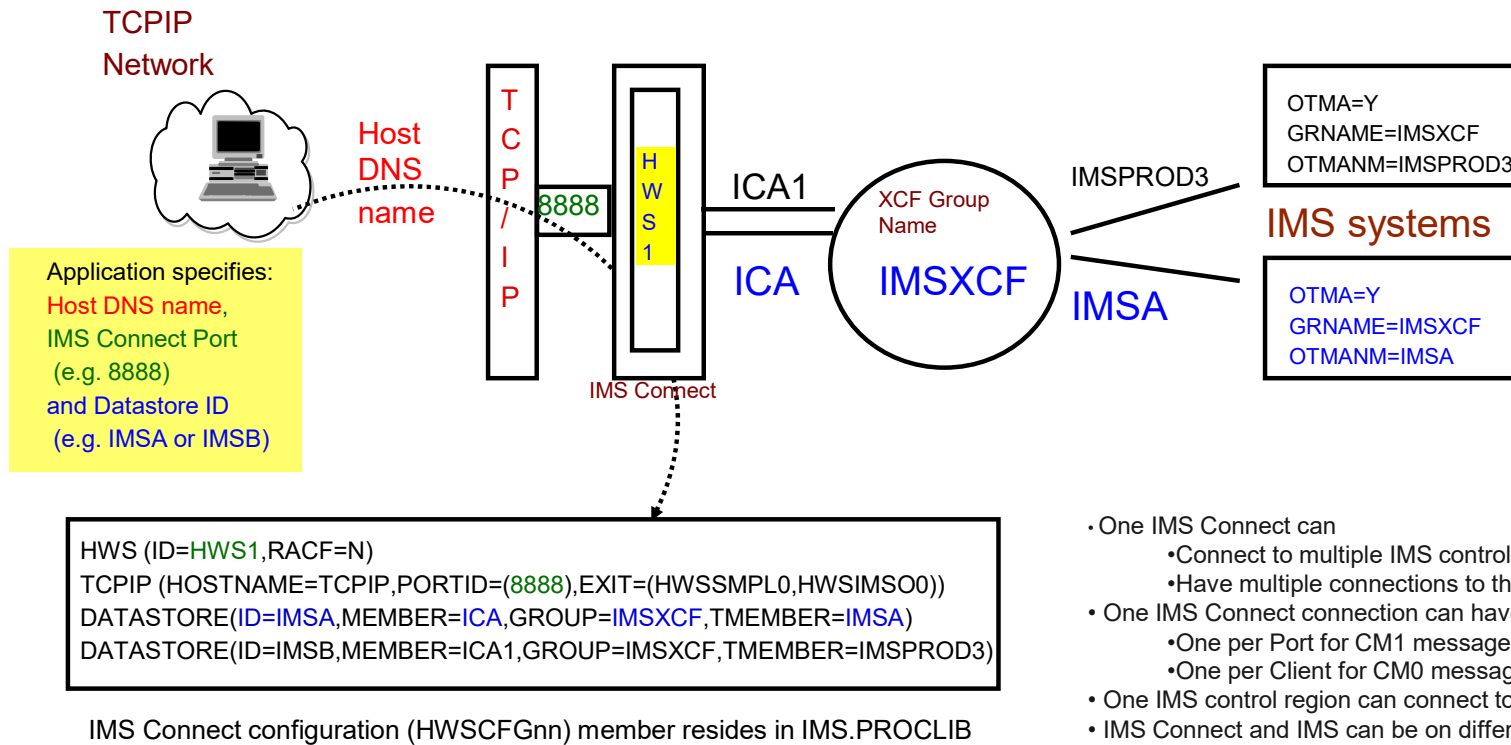

- One IMS Connect can
  - Connect to multiple IMS control regions in multiple XCF groups
  - Have multiple connections to the same IMS copy
- One IMS Connect connection can have multiple TPIPEs
  - One per Port for CM1 messages
  - One per Client for CM0 messages
- One IMS control region can connect to multiple IMS Connect instances
- IMS Connect and IMS can be on different LPARs in the same Sysplex

# IMS Connect and OTMA

## – Basic message flow for transactions

- **Client**

- Prepares the message and uses socket calls

- **IMS Connect**

- Receives the input message from the client via TCP/IP
- Passes the input message to a User Message Exit for formatting to OTMA input format
- Sends the input message to IMS OTMA

- **OTMA – processes the transaction**

- **IMS Connect**

- Receives the response message from IMS OTMA
- Passes the response message to the same User Message Exit for formatting to the TCP/IP client output format
- Sends the response message via TCP/IP

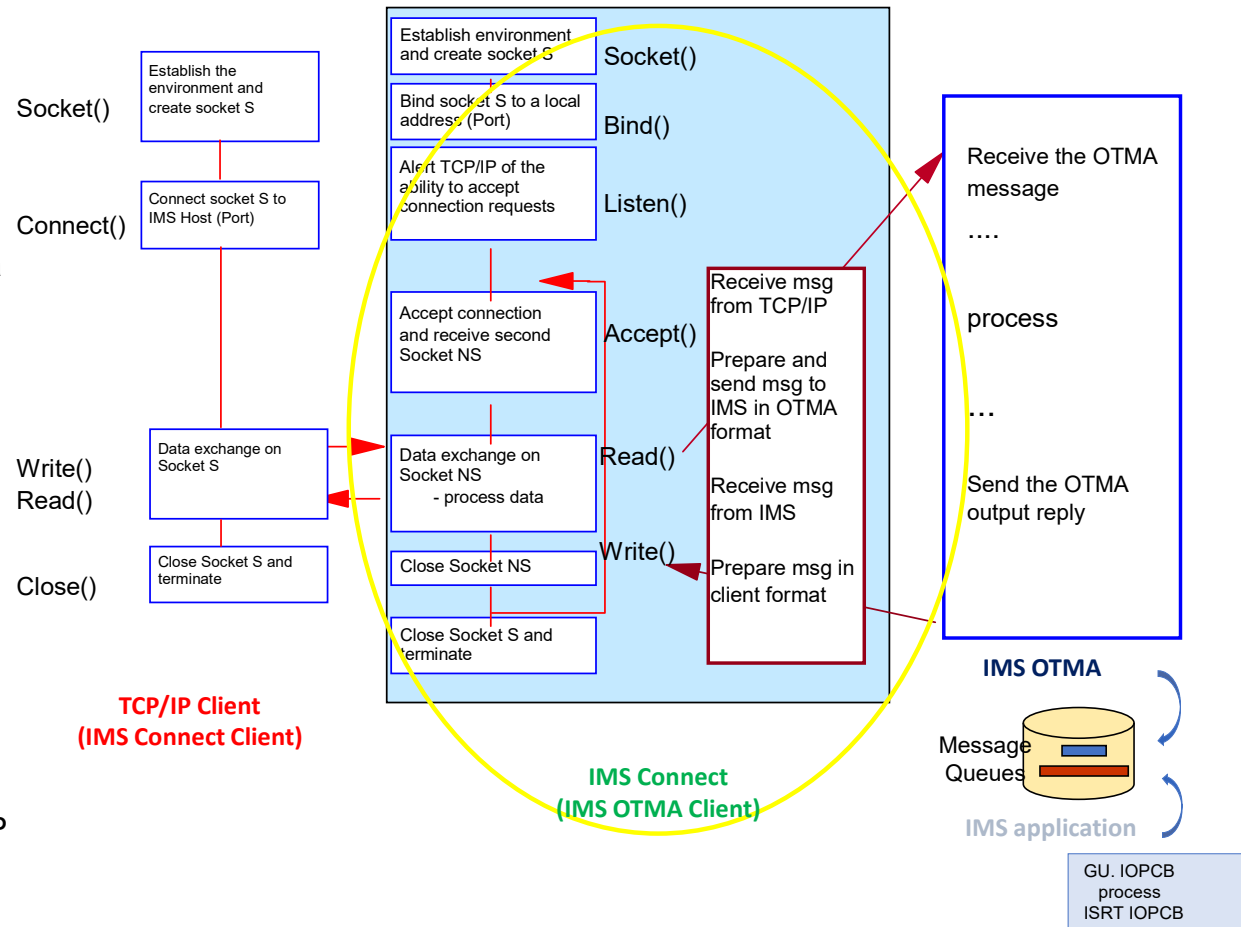



# IMS Connect Application Protocol - Transactions

- Messages between IMS Connect and IMS carry the OTMA prefix
  - IMS Connect application protocol provides a simplified header interface (IRM header)

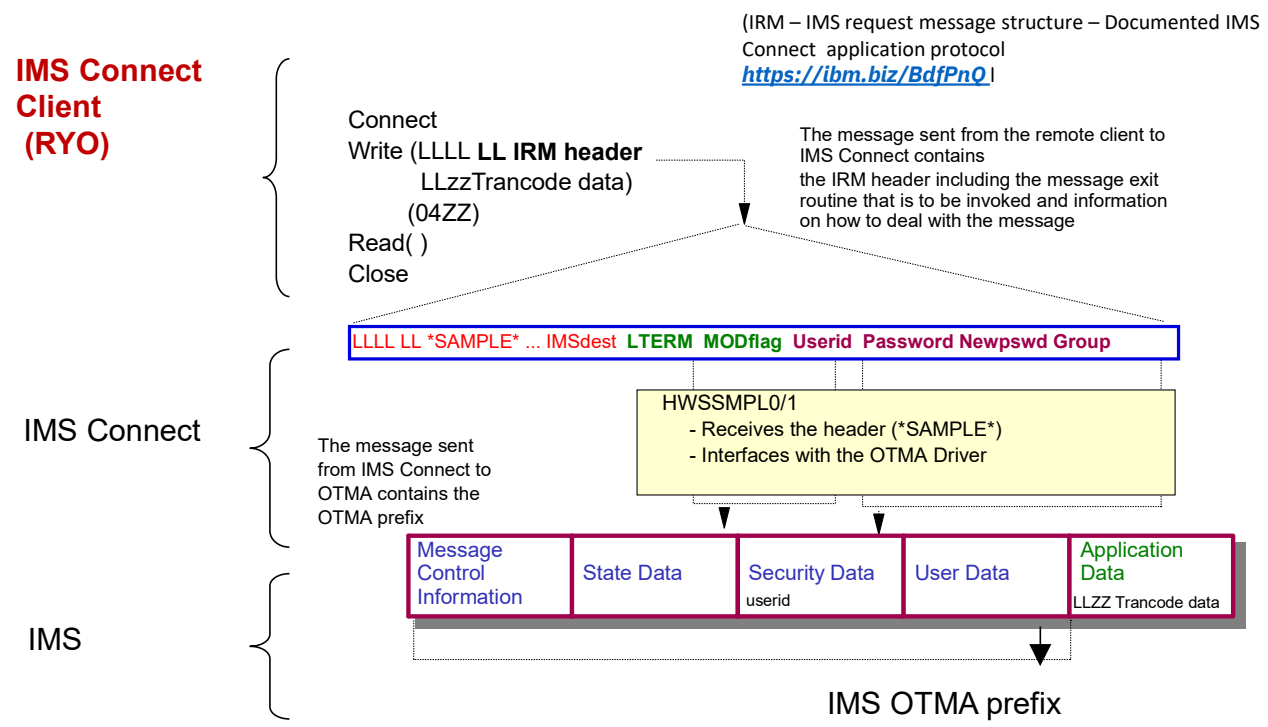

<https://tinyurl.com/tccv6u6>

- **Output messages**
  - **CSMOKY (Complete Status Message)**
    - Sent by IMS Connect upon successful interaction with IMS
  - **RMM (Request Mod Message)**
    - Returned as the first structure of an output message if the MFS mod name was requested
  - **RSM (Request Status Message)**
    - Sent by IMS Connect upon rejection of an inbound request
    - Return and reason codes are documented in the IMS Connect manuals
  - **Outbound application reply message**
  - **COR (Synchronous Callout Correlator Token)**
    - Provides the necessary token for IMS to tie the request and reply together

# IMS Connect Application Protocol – Transactions...



- **With a protocol to support IMS applications as clients**
  - Asynchronous
    - IMS applications send a message out using ISRT, ALTPCB
  - Synchronous
    - IMS applications use the ICAL to send a message and wait for a response
- **Resume TPIPE** - specified by remote programs to retrieve messages that originate in IMS applications

## Asynchronous

RESUME TPIPE - specify tpipe name used in ALTPCB or descriptor  
RECEIVE - receive ISRT output msg  
ACK - acknowledge receipt of first msg

## Synchronous

RESUME TPIPE – specify tpipe specified in the descriptor  
- application specifies descriptor  
RECEIVE - receive ICAL msg including a correlation token  
> the token is used to tie the input to the output for the program waiting in the dependent regions  
ACK - acknowledge receipt of msg  
... (process message and preserve the correlation token)  
SEND - response message must include the correlation token

# IMS Connect Application Protocol – Transactions...



- And architected clients for IMS Connect (downloadable and provided by IMS)
  - IMS TM Resource Adapter – IMS TM RA (<https://ibm.biz/~aFO4kHpun>)
    - Implements the Java EE Connector Architecture (JCA)
    - **Development:** runs in an integrated development environment (IDE) as a J2C feature and generates J2C applications, EJB components, Web services, either as stand-alone programs, or as added functionality to existing applications.
    - **Runtime:** runs in any generic Java EE 1.4 or later applications server, e.g., WebSphere Application Server (WAS), WebSphere Liberty, WebSphere Transformation Extender (WTX), IBM Integration Bus..
      - Connects IMS to the Java EE platform with the ability to leverage the qualities of service that are available on a Java EE application server
        - *Connection management, transaction management, and security management*

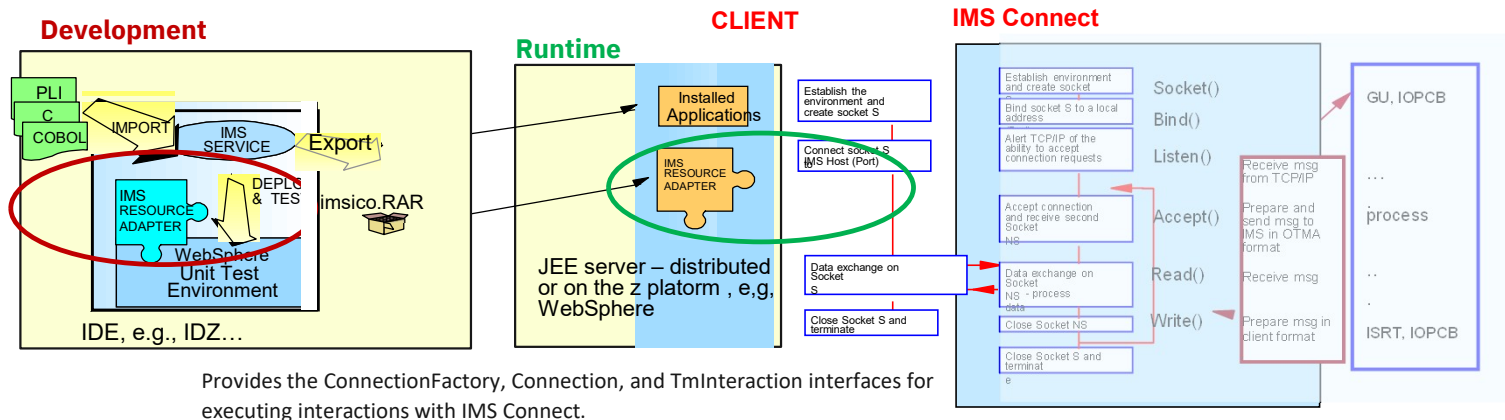



## IMS Connect Application Protocol – Transactions...

- And architected clients ...
  - IMS Connect API for Java
    - Opens connections to IMS connect on behalf of the client application
    - Provides client applications with programmatic control of connections
    - Assembles messages to send to IMS Connect, including the IMS request message (IRM) header
    - Manages the IMS Connect message protocol by sending and receiving the appropriate messages for interactions with IMS Connect
  - IMS Explorer for Development (<https://ibm.biz/BdPZZ>)
    - Eclipse-based graphical tool that simplifies common IMS tasks that are related to IMS application development and IMS database and program view definition.
    - Supports access to test IMS transactions (using IMS TMRA)
    - Supports access to IMS databases (using IMS universal drivers)
  - **WEBUI – browser-based** (<https://ibm.biz/~q8QOLHcLI>)

# IMS Connect Application Protocol – Transactions...



- Along with the ability to enhance connectivity between systems
  - Migrate ISC (SNA LU 6.1 Intersystem communication protocol) from VTAM to TCP/IP
    - IMS-CICS , IMS-IMS, CICS-IMS

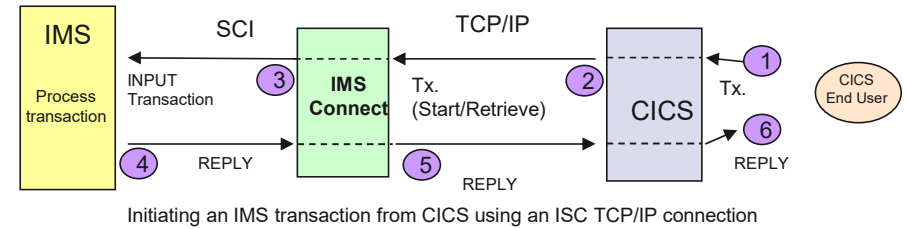
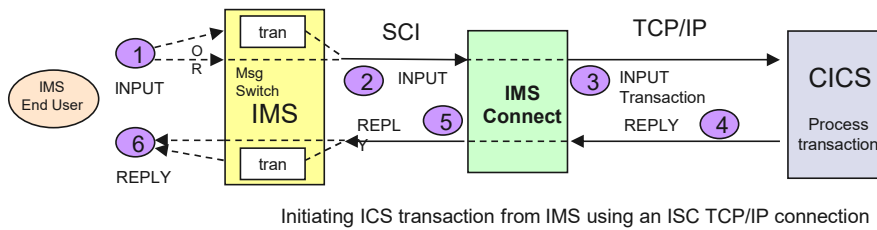

- Migrate MSC (IMS-IMS) connectivity from SNA VTAM to TCP/IP

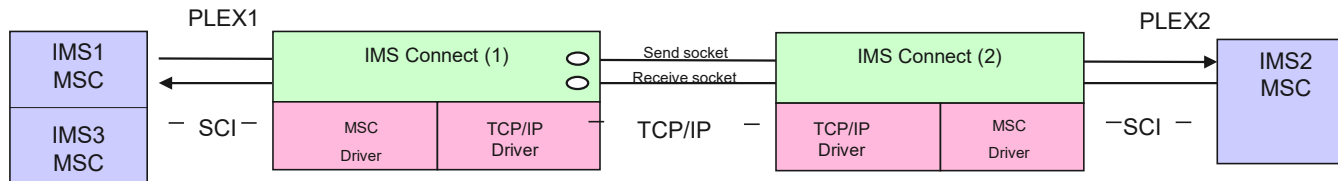

- Support the sending of messages (Program-to-Program switch) from one IMS to another using TCP/IP





## With the Ability to Control the Environment

- Remote programs control the flow with IMS Connect/IMS
  - Send-Receive (write – read): send a message and wait for a reply (IOPCB)
  - Send-Only: request one-way communication
  - Resume TPIPE: receive unsolicited responses from IMS (ALTPCB and ICAL)
  - Send with additional directions for error conditions
    - Reroute undeliverable reply - If the output reply cannot be delivered to sender, reroute elsewhere
    - Purge undeliverable reply - If the output cannot be delivered to sender, delete it
    - ...
- IMS Connect Interacts with IMS to support:
  - Full security
  - High Availability and Load Balancing
    - Supermember support
    - MultiRTP
  - Message Flood conditions
  - Timeouts
  - Interaction with OTMA to support ICAL, Transaction orchestration, etc.

## And a Way to Modify Its Own Behavior



- **IMS Connect exit routines provide a mechanism to modify IMS Connect behavior**

- Function-specific exit routines
  - HWSUINIT – Initialization/Termination
  - HWSPCH0 – Password change
  - IMSLSECX – Security
  - HWSTECL0 – for event recording (performance and data analysis)
    - Used by IMS Connect Extensions
  - ODBM support (database)
    - HWSAUTH0 – ODBM support - DB security exit
    - HWSROUT0 – ODBM support - DB routing exit
- Message Exit routines – affect each message
  - Before being sent to IMS (ebcdic – ascii)
  - Before being sent to the remote client (ascii – ebcdic)
  - Are unique to different IMS Connect client types
    - Provided and do not need to be modified unless required to change default actions

Message Exit routines – affect each message...

HWSSMPL0/1

Standard exit routine for user-written clients and for many 3<sup>rd</sup> party vendors

HWSJAVA0

Supports requests from the IMS TM Resource adapter (JCA adapter) from environments such as WebSphere application server, JEE servers, z/OS Connect, ....

HWSOAP1

Supports requests from the IMS Soap Gateway

HWSDPWR1

Supports interactions with DataPower appliances

HWSCSLO0/1

Supports interactions with the Operations Manager (OM) component of the IMS common service layer (CSL)

Port Input/Output Edit Exit

Receives message on entry to IMS Connect and right before sending reply to client

Can be used when communicating with clients whose formatting is inconsistent with IMS Connect

# IMS Connect – What's new – Continuous Delivery



## IMS 15 IMS Connect Enhancements – <https://www.ibm.com/docs/en/ims/15.5.0?topic=enhancements-ims-connect>

<https://www.ibm.com/docs/en/ims/15.6.0?topic=enhancements-ims-connect>

- **PH51844/UI92221**
  - RACF PassTicket support for commands from IMS Connect to IMS OM
    - Authentication of user IDs for IMS Connect connections to IMS Operations Manager by using RACF PassTickets. The IMS Connect API (ICON API) for Java™ is also enhanced to accommodate this enhancement.
- **PH41890/UI81659**
  - IMS Connect send-only with error protocol enhancement
    - Clients can request to receive the errors that occur in IMS
- **PH14651/UI65540**
  - Password Phrase enhancement
    - IMS Connect is enhanced to support password phrases with 9 - 100 characters for IMS database clients using Open Database function and for IMS transaction manager user-provided clients using HWSSMPL0, HWSSMPL1, or equivalent user-defined exit routines.
- **PH07679/UI62878**
  - ODBM RAS U210 enhancement
    - IMS Connect has been enhanced to prevent U210 abend in IMS when UDB applications terminate with work in progress.
- **PI99040/UI58288, PH02135/UI58345**
  - RACF PassTicket support for DRDA clients enhancement
    - RACF PassTicket support for authentication of users who access an IMS database from IMS Connect clients that use the Distributed Relational Database Architecture™ (DRDA) protocol.

## IMS Connect – What's new – Continuous Delivery



- **PI91859/UI55921**
  - IMS Connect message HWSC0010I enhancement
    - Message HWSC0010I is enhanced to be issued after IMS Connect initialization is complete. With this enhancement, system administrators can start automated operations after message HWSC0010I is issued to ensure that their automated operations and requests are processed by IMS Connect.
- **PI94909/UI55527**
  - Generic return code enhancement for RACF verifications(IMS CONNECT - RACFGENRC OPTION)
    - The RACFGENRC= parameter is added to the HWS statement of the HWSCFGxx member of the IMS PROCLIB data set to allow you to specify whether a generic return code or message is returned by IMS Connect. The generic return code or message is issued if RACF is used to verify sign-ons from IMS Connect clients and the user ID or password provided is invalid.

So ...



- **For transaction access**

- IMS Connect supports many variations of what has been discussed
  - You can write your own client or leverage solutions that have been provided
- IMS provides IMS Connect client code or interfaces that have been implemented in a variety of environments
  - DataPower, JEE servers, e.g., WebSphere application server; z/OS Connect support for REST APIs, 3<sup>rd</sup> party vendor products
- **Note:** Support and troubleshooting requires a basic knowledge of the OTMA and IMS Connect interactions

- **What about Database?**

## IMS Connect – ODBM (Open Database Manager)

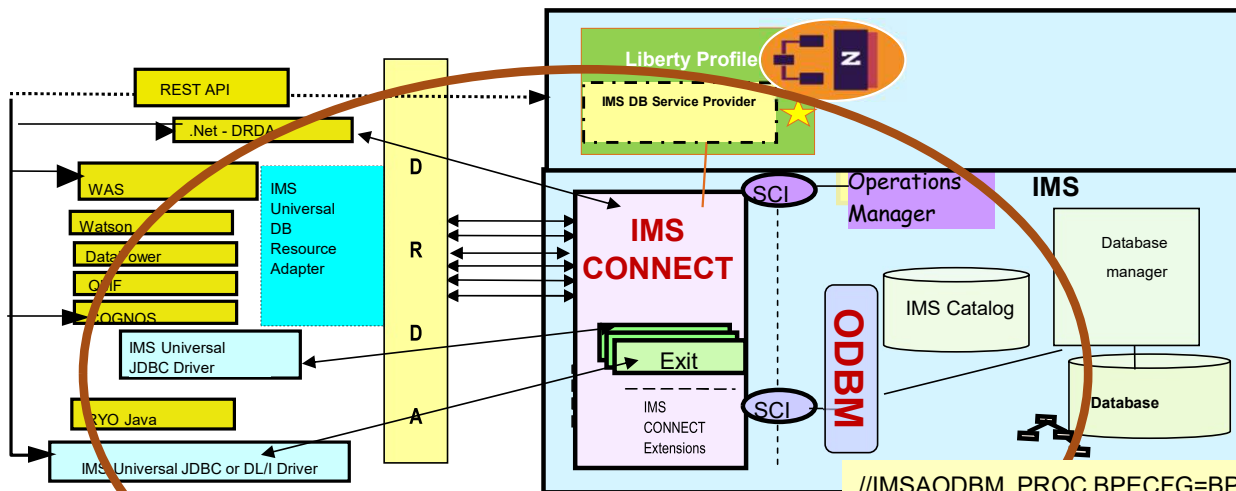

```
//IMSAODBM PROC BPECFG=BPEODBM,
//  ODBMINIT=00A,
//  CSLDI=CSLDINI0,
//  PARM1='RRS=Y,ARMRST=N'
//*
//ODBM EXEC PGM=BPEINI00,REGION=0M,TIME=NOLIMIT,
// PARM='BPECFG=&BPECFG,BPEINIT=&CSLDI,ODBMINIT=&ODBMINIT,&PARM1'
//STEPLIB DD DSN=IMS.IMSA.SDFSRESL,DISP=SHR
// DD DSN=SYS1.CSSLIB,DISP=SHR
//PROCLIB DD DSN=IMS.IMSA.PROCLIB,DISP=SHR
//SYSPRINT DD SYSOUT=X
//SYSUDUMP DD SYSOUT=X
//CCTL SNAP DD SYSOUT=X
```

## Open Database – Value Proposition



- **Open Database provides an environment that manages access to online IMS databases from anywhere in the enterprise**
  - Supports Open standards for connectivity to online IMS databases
    - *Within and across z/OS LPARs as well as from distributed platforms*
      - Allows more flexibility in accessing IMS data to meet growth challenges
      - Allows IMS databases to be processed as a standards-based data server
  - Goal: ease application development access to IMS databases

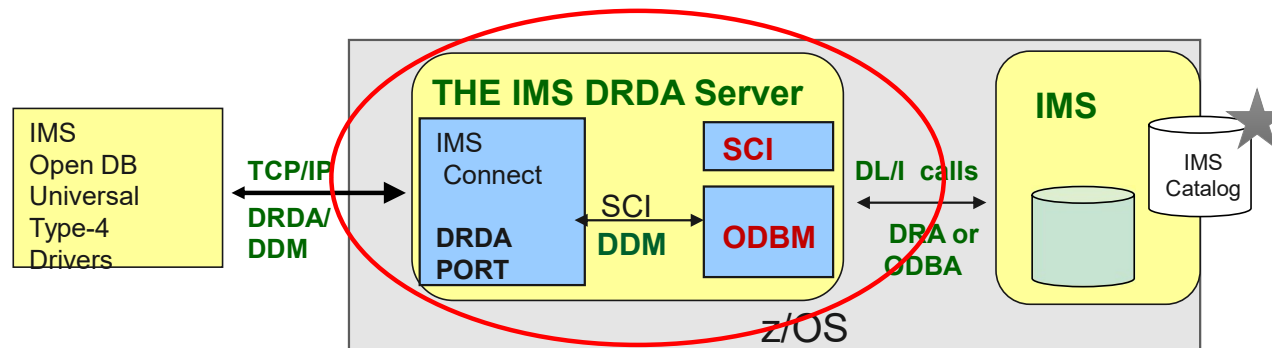

## Open Database



- **ODBM supports three interfaces:**

- From CSL ODBM clients
  - Communicate with ODBM with CSLxxxxx calls
- From ODBA address spaces
  - An ODBA interface (used by ODBA application AERTDLI call)
  - Calls are relayed to IMS ODBA
- From IMS Connect (this is the only interface we will discuss in this presentation)
  - ODBM receives database connection requests from IMS Connect as DDM commands
  - Translates incoming database requests from the DDM protocol into DLI calls expected by IMS
  - Translates responses to the client into the DDM protocol

## Open Database - DRDA Server

- **IMS Connect**

- Supports DRDA “Distributed Relational Database Architecture”
  - an open standards-based protocol for distributed database access
  - Works even though IMS is Hierarchical
- Defines request flows
- Defines Object: Data structure (DDM – Distributed Data Management)

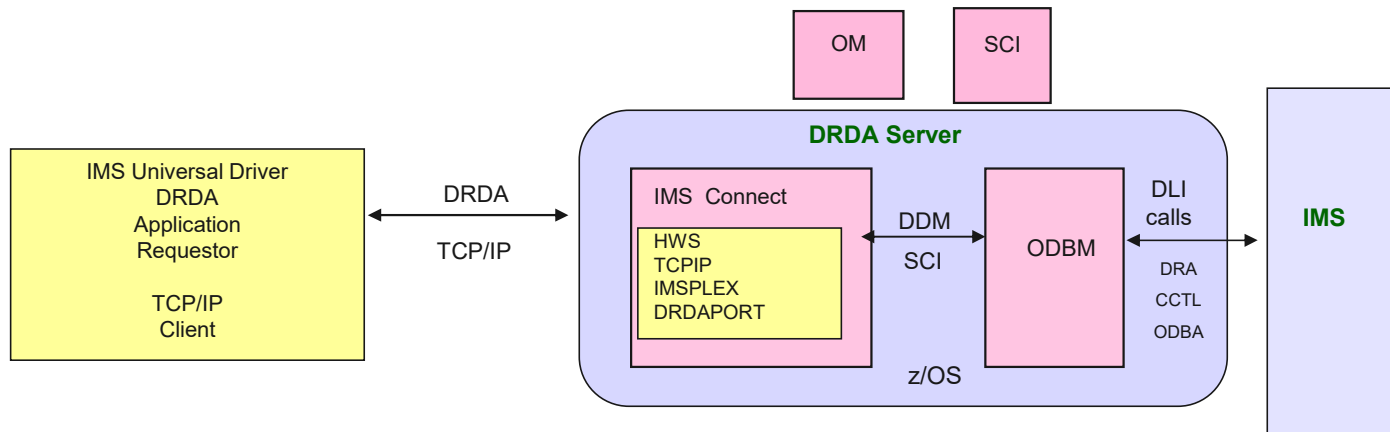

## Open Database - DRDA Server ...



- **ODBM**

- Interprets DDM and issues DLI calls to IMS
  - **Receives** database connection requests from IMS Connect
  - **Translates** incoming database requests from the DDM protocol into DLI calls expected by IMS
  - **Translates** responses to the client into the DDM protocol
  - **Manages** connections to IMS DB
    - *Implements the DRA interface*
- **Supports** Global Two-phase commit semantics
  - RRS=Y RRS provides sync point coordinator role
- **Supports** Local Single-phase commit semantics
  - RRS=N syncpoint management must be performed by the ODBM client.

## Open Database – Client Support



- **IMS Universal drivers**

- Provide Java applications with connectivity and access to IMS databases
  - **IMS Universal DB Resource Adapter** - Provides JDBC SQL access to IMS data in a JEE environment such as WebSphere Application Server (WAS) on any platform
  - **IMS Universal JDBC driver** – Provides JDBC SQL access to IMS data in a Non-JEE environment such as stand-alone java, DB2 SP, IMS TM, CICS
  - **IMS Universal DL/I driver** - Provides the ability to issue calls that are similar to DL/I directly to IMS from a Non-JEE Java environment

- IMS supports both data access and data manipulation

- SELECT – Retrieve data
- INSERT – inserts data
- UPDATE – updates data
- DELETE – deletes data
- Also supports DDL for data definition and data administration
  - CREATE DATABASE, TABLE
  - ALTER DATABASE
  - etc...



# Metadata: Heirarchical – Relational Mapping

IMS universal drivers provide the ability to view an IMS hierarchical database as though it was a set of relational tables

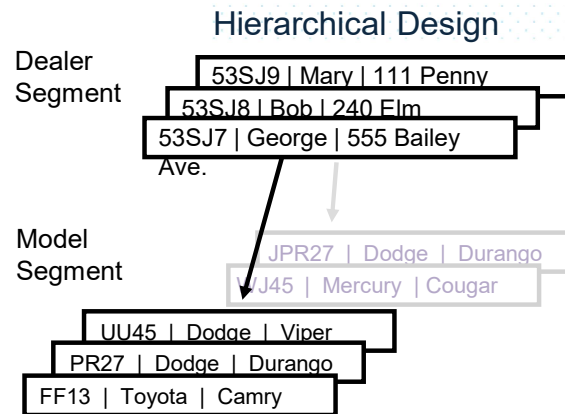

**Note:** Segment Names ~ Table Names  
 Segment Instances ~ Table Rows  
 Field Names ~ Column Names

```
SQL: SELECT Dealer.Name, Dealer.Phone, Order.LastName
FROM SomePCB.Order
WHERE Model.MSRP>'50000'
AND Order.Date>='5/1/2007'
AND Order.Date<='5/31/2007'

SSA LIST: DEALER
MODEL
ORDER
```

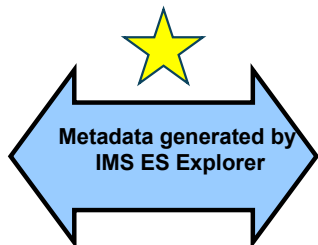

## Relational Design

**Dealer Table**

	DealerID	DealerName	DealerAddress
0	53SJ7	George	555 Bailey Ave.
1	53SJ8	Bob	240 Elm St.
2	53SJ9	Mary	111 Penny Ln.
...	...	...	...

**Model Table**

ID	Make	Model	Dealer	
UU45	Dodge	Viper	53SJ7	0
PR27	Dodge	Durango	53SJ7	0
FF13	Toyota	Camry	53SJ7	0
JR27	Dodge	Durango	53SJ8	1
WJ45	Mercury	Cougar	53SJ8	1
...	...	...	...	...

Relational JOIN

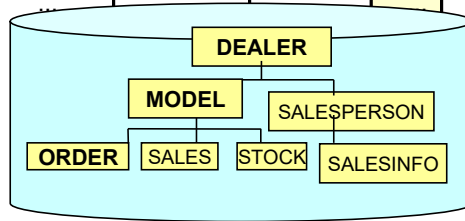

## IMS Even Provides a Tool – IMS Explorer for Development (E4D)

- SQL to DLI conversion requires a relational view and metadata of the IMS DBs
  - IMS Metadata
    - Defines Java names, View/PCB. Tables/segment, Column/field,
    - Defines data type of each column
  - Used by JDBC driver to convert SQL call into DL/I equivalent
    - Generated by the IMS Enterprise Suite Explorer for Development
      - Downloadable and no charge tool

- IMS database visualization tool**
  - Visualize an entire IMS PSB
  - Can view and print each PCB individually
    - Hierarchy, segments, fields, types, etc
- IMS database metadata generation tool**
  - Generates the necessary metadata that is consumed at runtime by IMS JDBC driver
    - Database metadata
- Interacts with the IMS Catalog**
  - Retrieves metadata that is already in the catalog

★ Support for DDL

Eclipse tool

Web UI is available

The screenshot shows the IMS Explorer for Development (E4D) interface. It features a hierarchical tree view of database segments and fields, a SQL query editor, and a results table. The results table displays data for a query on the HOSPITAL table, showing columns for HOSPLL, HOSPCODE, and HOSPNAME. The data rows are:

HOSPLL	HOSPCODE	HOSPNAME
L	R1210010000A	ALEXANDRIA
L	R1210020000A	SANTA TERESA
L	R1210030000A	SANTA CLARA
L	R1210040000A	NEW ENGLAND

Annotations on the screenshot include:

- A green arrow pointing to the SQL editor with the text "Access IMS data with SQL queries".
- An orange arrow pointing to the tree view with the text "Edit fields in the DBD".
- A green arrow pointing to the tree view with the text "See database relationships change DBD field attributes".



# Remote Access to IMS Databases

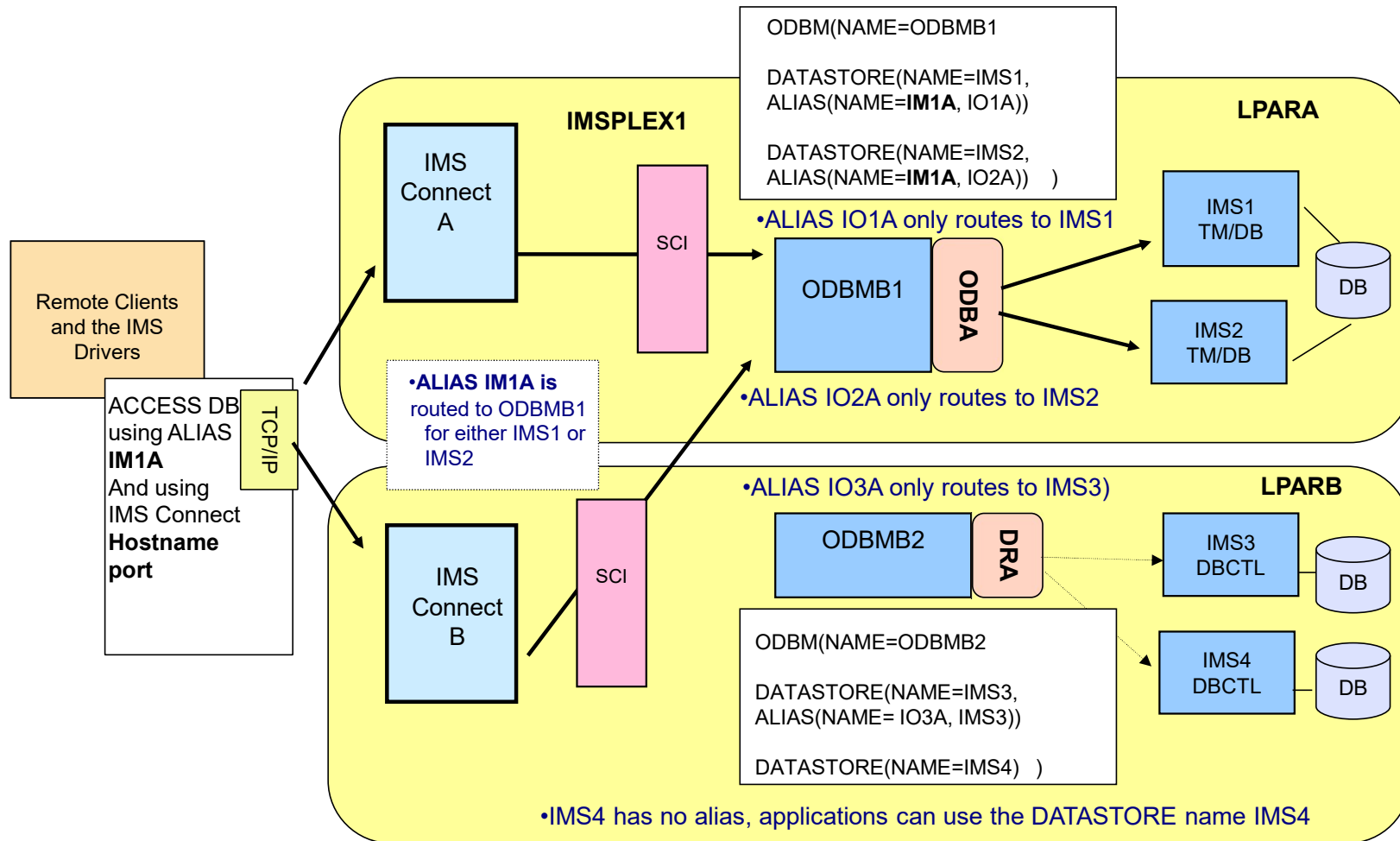

## ODBM – What's new – Continuous Delivery



### IMS 15 IMS Open Database Enhancements –

<https://www.ibm.com/docs/en/ims/15.6.0?topic=enhancements-ims-database-manager>

- **PH14157/UI64958**
  - ByteBuffers in the IMS Universal JDBC and DL/I Interfaces
    - All users of IMS Universal Driver running IMS 15 or later can use byte buffers as an I/O area to INSERT, SELECT, and UPDATE full segment areas from an SQL query. A new interface for issuing ICAL and enhanced support for Dynamic Arrays and ArrayResultSets have also been added.
- **PH03426 for IMS Universal Drivers**
  - Database segment mapping enhancement
    - The database segment mapping enhancement allows application developers to access an IMS database segment whose schema is determined by the key feedback data from a parent segment without knowledge of the database schema.
- **PH02698/UI58748PH00366/UI58745**
  - Open Database Manager (ODBM) and JDBC driver support for INIT STATUS Group call
    - ODBM allows an INIT STATUS GROUPx call from an application by using IMS Universal Drivers (UDB). Issuing the INIT STATUS GROUPA call avoids ABEND U3303 and issuing the INIT STATUS GROUPB call avoids ABEND U0777.



## ODBM – What's new – Continuous Delivery...

- **PH43314/PTF UI79944**
  - DDL enhancement
  - <https://www.ibm.com/docs/en/ims/15.3.0?topic=enhancements-ims-data-definition-utility-dfs3id00-enhancement>
    - Support for the IMS Data Definition utility (DFS3ID00) to submit Data Definition Language (DDL) SQL statements natively without the need of IMS Connect and ODBM address spaces.
- **PI94682/UI56399**
  - ODBM Security Options Enhancement
    - Enhanced ODBMSECURE parameter to specify whether IMS performs security checking on a PSB resource for an ODBM thread at the time of the allocate PSB (APSB) request.
- **PI95663/UI57273**
  - IMS Universal Database resource adapter connectivity enhancement for WebSphere Application Server Liberty
    - The IMS Universal Database resource adapter is enhanced to provide type-2 and type-4 connectivity support for WebSphere Application Server Liberty.

# So...IMS Connect, OTMA, ODBM

Provide the infrastructure that enables integration to IMS resources

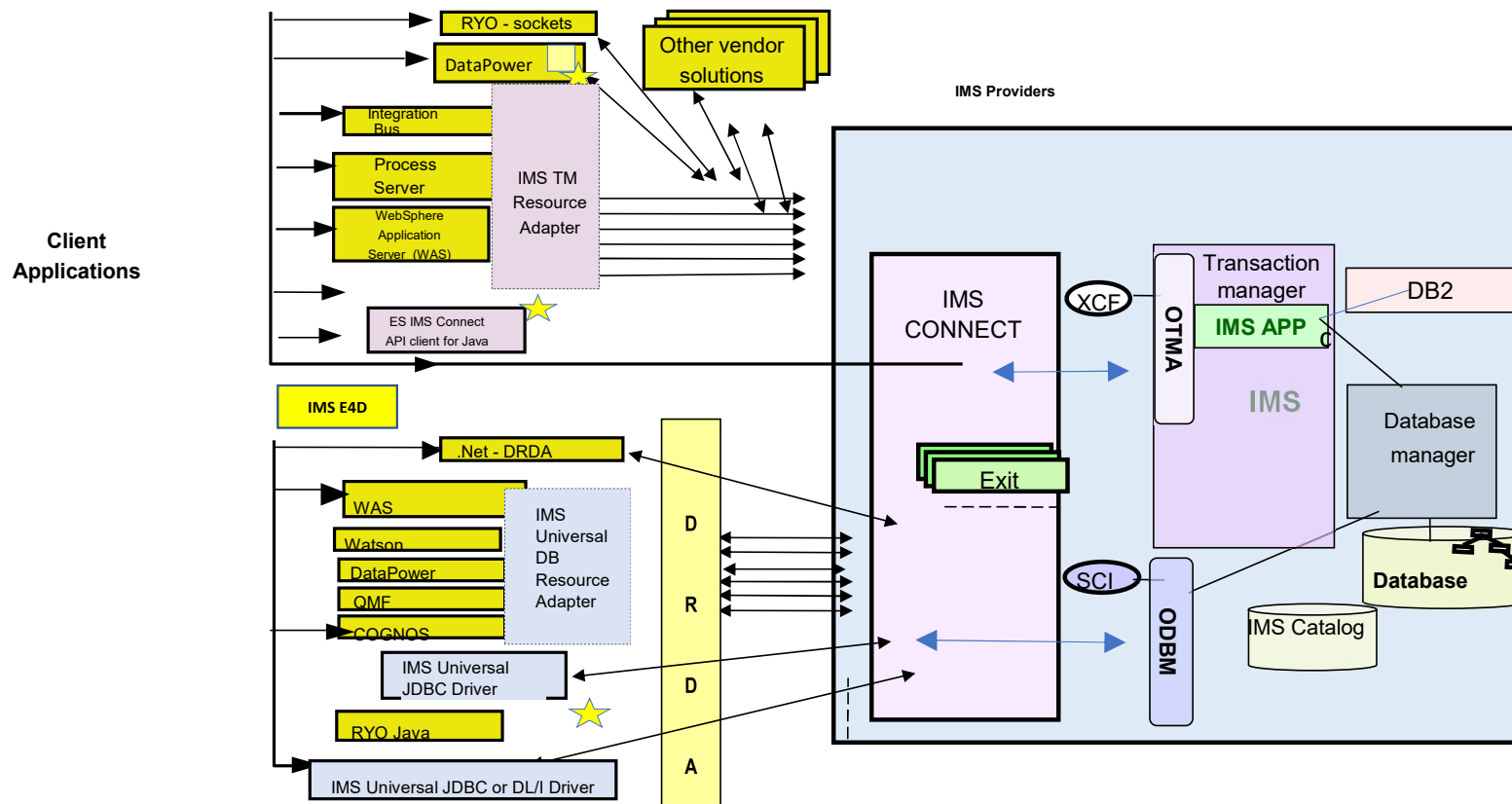

# So...IMS Connect, OTMA, ODBM



... And with the technical architecture in place, these components facilitate integration with ever evolving technologies  
 --- For Example, REST APIs and z/OS Connect

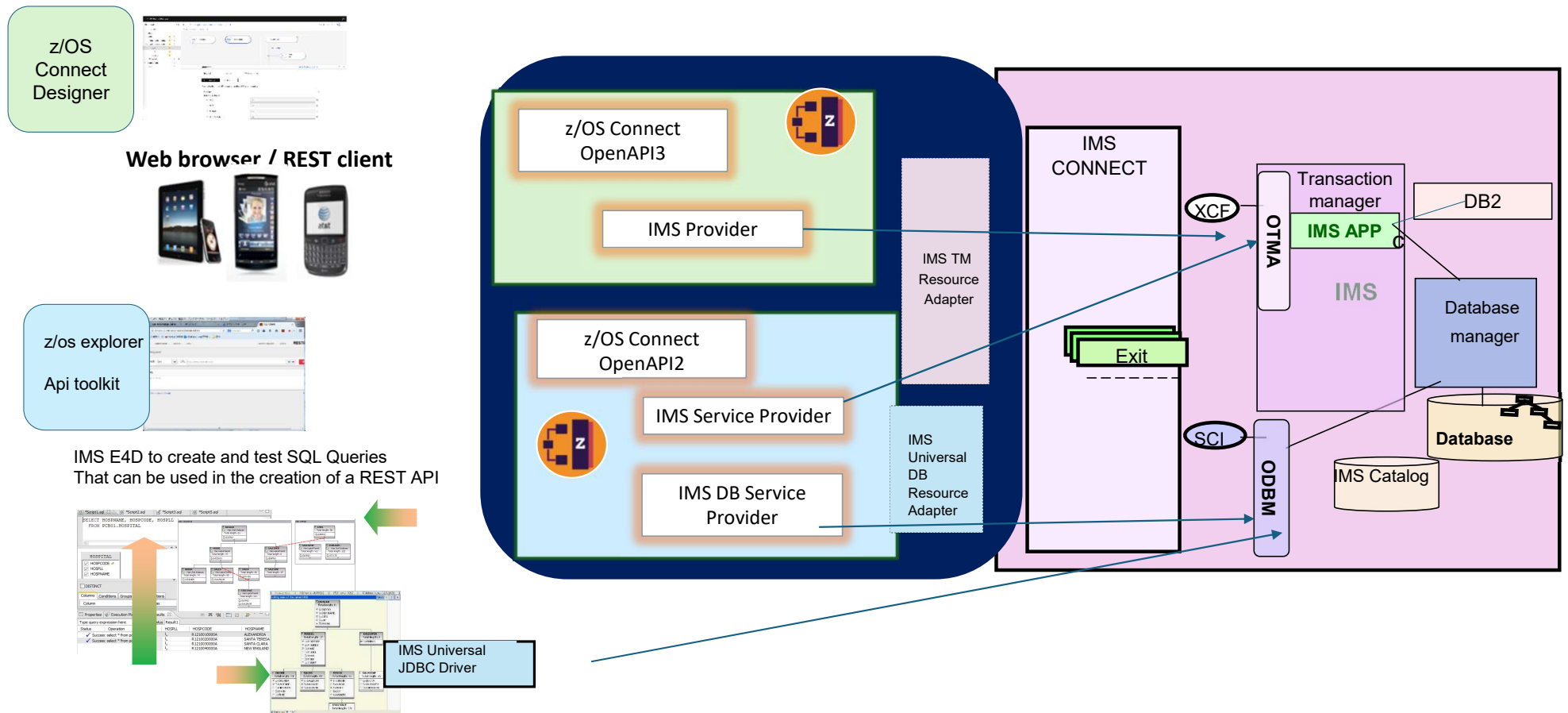

## So...IMS Connect, OTMA, ODBM

... Which enables resilient support for strategic solutions without changing IMS

- **Cloud**
  - Ability to quickly deploy new services
  - Ability to allow on premise provisioning of IMS resources w/o an outage
- **Analytics**
  - Adding quickly and easily re-deploy applications after adding analytics
- **Mobile**
  - Scale due to increase loads
  - Enhance information
  - Maintain availability for 24x7 access
- **Bottom line: Ability to deploy strategic initiatives in IMS without impacting your existing availability**

