

# Dynamic Resources & The IMS Repository (IMSRSC): What, Why, and How



Ashley Lopez  
Worldwide Systems Center Advisory  
IMS Technical Enablement Specialist  
ashlopez@ibm.com

# Agenda



WHAT



WHY



HOW



THE VALUE

## *IMS Repository – What is it?*

- A ‘repository’ is a generalized data storage facility that can be used to store various types of information
- The **IMS repository** function is a centralized method for storing and retrieving resource definitions in an IMSplex
  - Enables multiple IMS systems in a single or multiple-IMS IMSplex to manage, store, share, and retrieve resource definitions
- **Focus:** improve the systems management and resource management aspects of handling IMS resource definitions
  - Across multiple IMSs or for a single standalone IMS

## IMS Repository Function Usage – the Why

- Supports IMS DRD (Dynamic Resource Definition)
- Stores resource and descriptor definitions for Dynamic Resource Definition (DRD) can be stored in an IMS repository
  - Contains resource definitions for **programs/transactions/databases/FP routing codes & descriptors**
    - Called the IMSRSC, the IMS resource definition repository
  - **Provides an alternative to using MODBLKs with SYSGEN and online change**
  - **Considered a strategic alternative to the RDDS (BSAM dataset that was originally introduced to support DRD)**
    - Replaces one or more sets of RDDSs in an IMSplex with a single repository
    - Eliminates the need to manually coordinate and manage separate RDDSs per IMS across a multiple-IMS IMSplex
- IMS can retrieve the stored resource definitions from the IMSRSC repository to dynamically generate runtime resources during a COLD START

## *IMS Repository Function Usage – the Why*

- **Additionally**
  - Changes made to active systems with the IMPORT SCOPE(ALL) command are applied to an inactive IMS when it is restarted
    - Resource lists for each IMS that uses the Repository
    - Support for generic definitions of a resource and specific attributes for an IMS if different
    - Change lists that contain resource and descriptor names that correspond to resource changes made for all the IMS systems with SCOPE(ALL) in a plex when an IMS is down
  - Simplifies IMSplex management
    - Easier to maintain synchronization of IMS systems' resources in a DRD with repository environment

# Usage

With DRD –resource definition changes can be made to a running system and rebuilt across all restarts

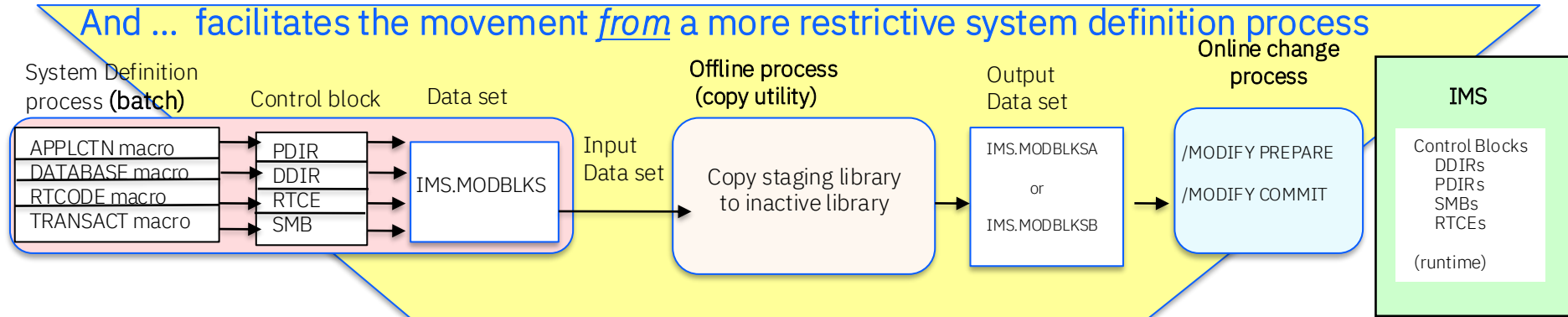

- **To Dynamic Resource Definition – DRD (for modblks resources)**

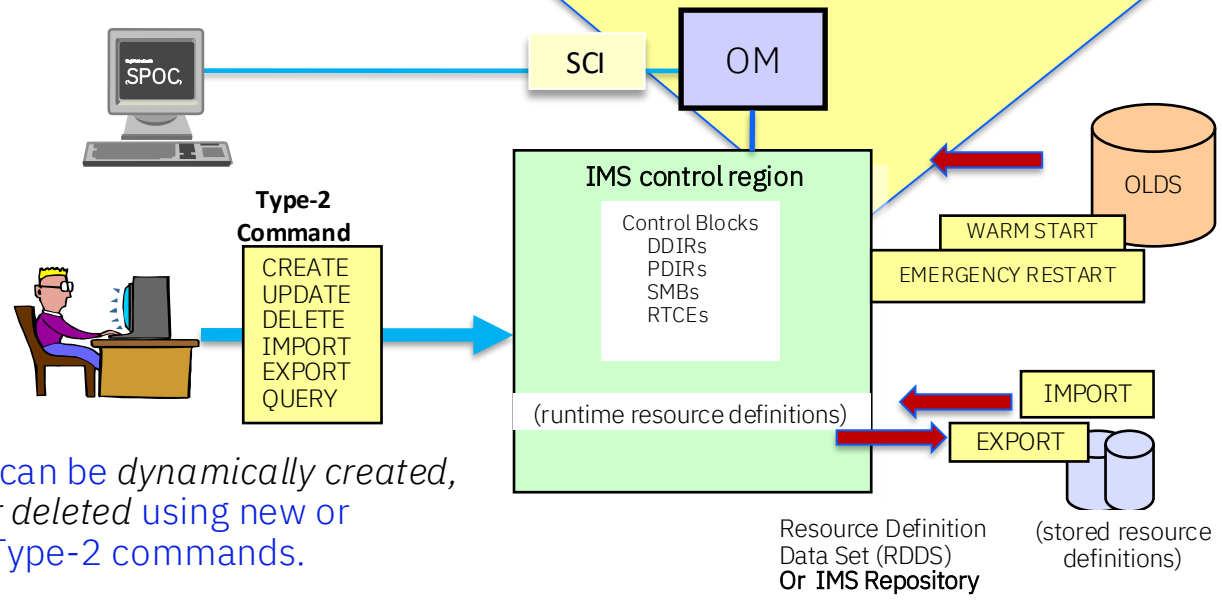

Definitions are logged when created, updated, or deleted, and at system checkpoint time and recovered from the logs during warm and emergency restart

During IMS cold start processing, resource definitions will be **IMPORTED** from RDDS/Repository

Definitions can be **EXPORTED** to the IMS Repository during simple or shutdown checkpoints or by command

Definitions can be *dynamically created, updated, or deleted* using new or enhanced Type-2 commands.

# IMS Repository Function Components

- A Repository Server (RS)
  - A new BPE-based address space managed by the Resource Manager (RM) CSL address space
- Repositories
  - Catalog repository
    - Used by the Repository Server
  - IMSRSC repository(s)
    - Contains DRD stored resource definitions
- A Common Service Layer (CSL) IMSplex configuration consisting of
  - Operations Manager (OM)
  - Resource Manager (RM)
  - Structured Call Interface (SCI)
  - SPOC for entering type-2 commands
  - Optional resource structure with CQS address space
- Batch utilities
  - Batch ADMIN utility for the repository FRPBATCH
  - RDDS to Repository CSLURP10
  - Repository to RDDS CSKURP20 (for fallback)
- Audit Log (optional) – ability to write to the z/OS logger audit log stream

# At a Glance

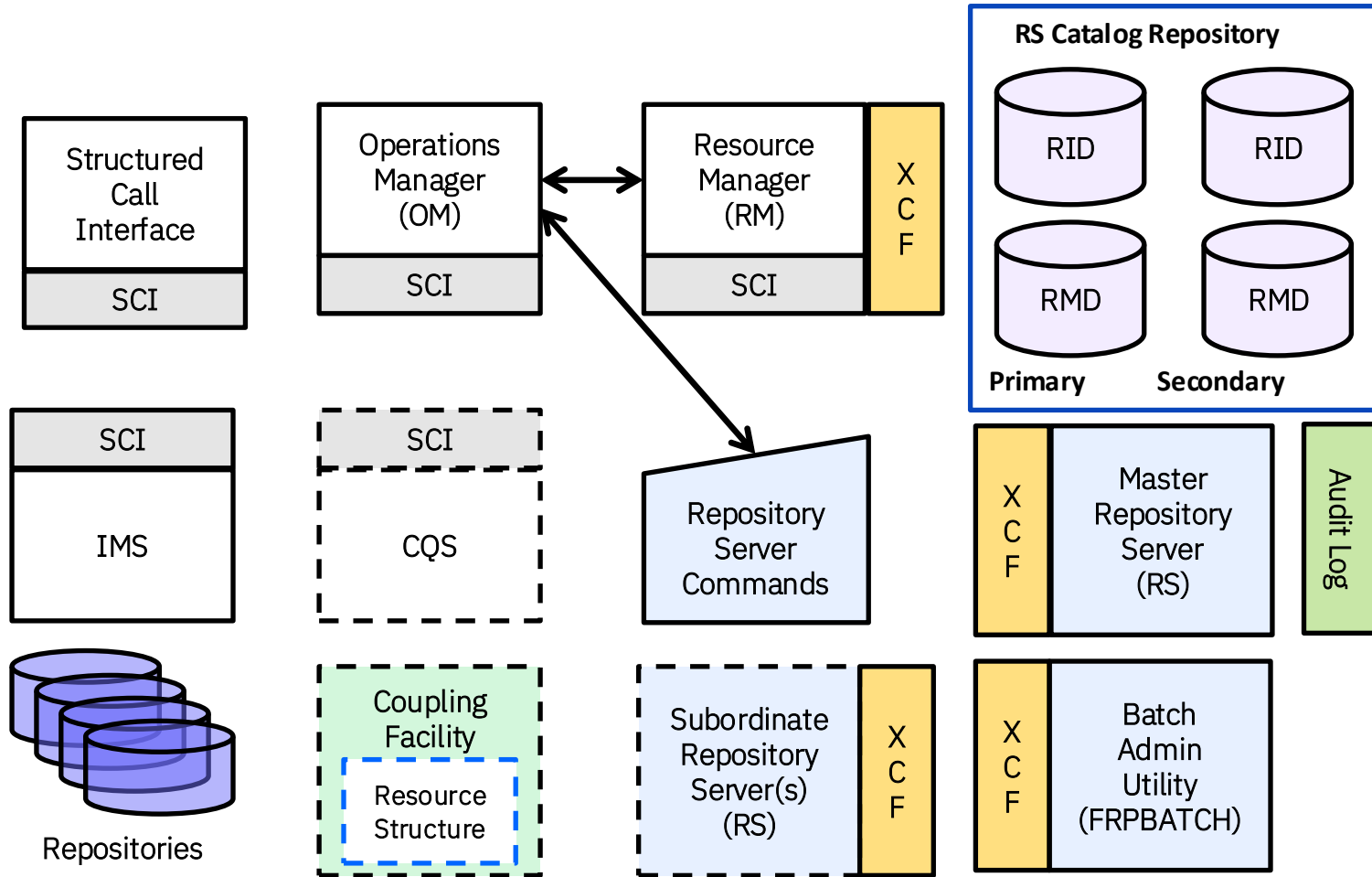

With a Little More Detail

# IMS Repository Function Components: Repository Server

- A Repository Server (RS)
  - A BPE-based address space
    - Managed by the Resource Manager (RM) CSL address space
  - Two types
    - Master repository server
      - Single instance
      - Manages access to repository data sets
      - First RS address space to access repository
    - Subordinate repository server
      - One or more instances
      - Used if master repository server goes down
      - **Optional but recommended**

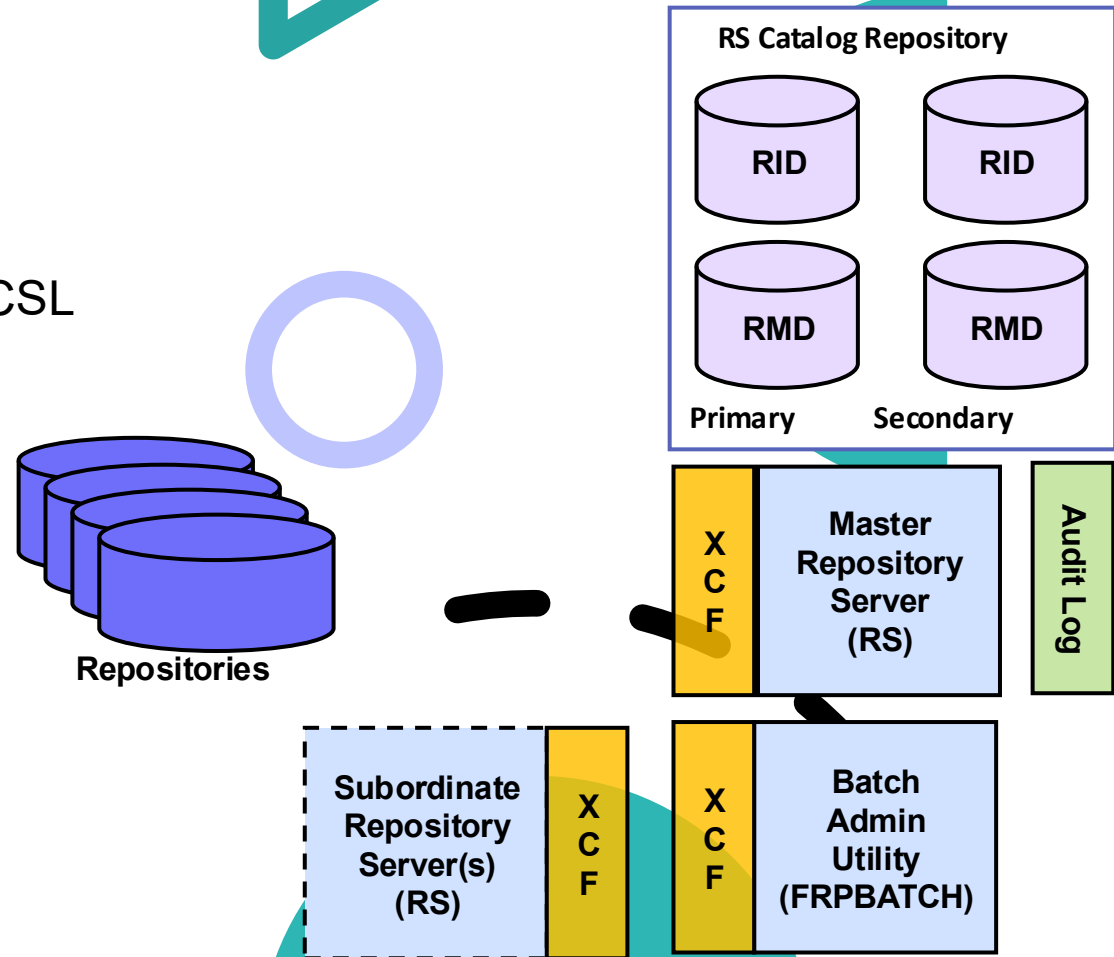

# IMS Repository Function Components: Repository Server

- A Repository Server (RS)...
  - Uses VSAM KSDS data sets to store information
  - Leverages z/OS XCF for server communications
  - Can be on a separate LPAR in the parallel sysplex (XCF)
  - One master repository server per IMSplex
    - This master repository server can manage definitions from other IMSplexes in the sysplex (XCF) as well as its own IMSplex within the same repository
  - Recommendation: one master repository server address space per IMSplex

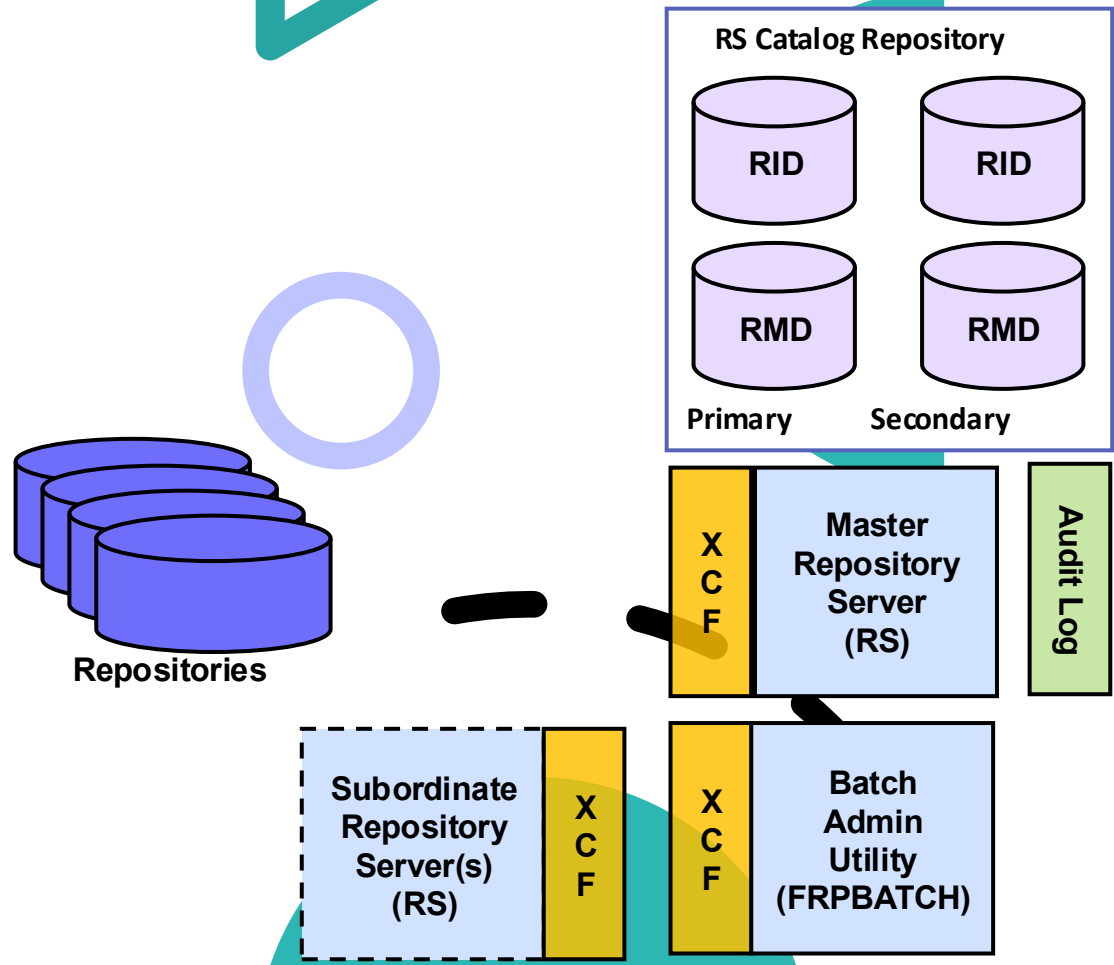

# IMS Repository Function Components: Repository Server

- A Repository Server (RS) – Internal Structure
  - Has its own internal repository called the ‘catalog repository’
  - Manages IMS repositories
    - IMS Catalog repository
    - IMS Resource repository (IMSRSC)
  - Manages registrations and connections to the repository
  - Ensures repository data integrity
  - Uses SAF to restrict access to repositories
  - Optionally, provides an audit trail using the z/OS logger
  - Provides tracing capabilities via BPE

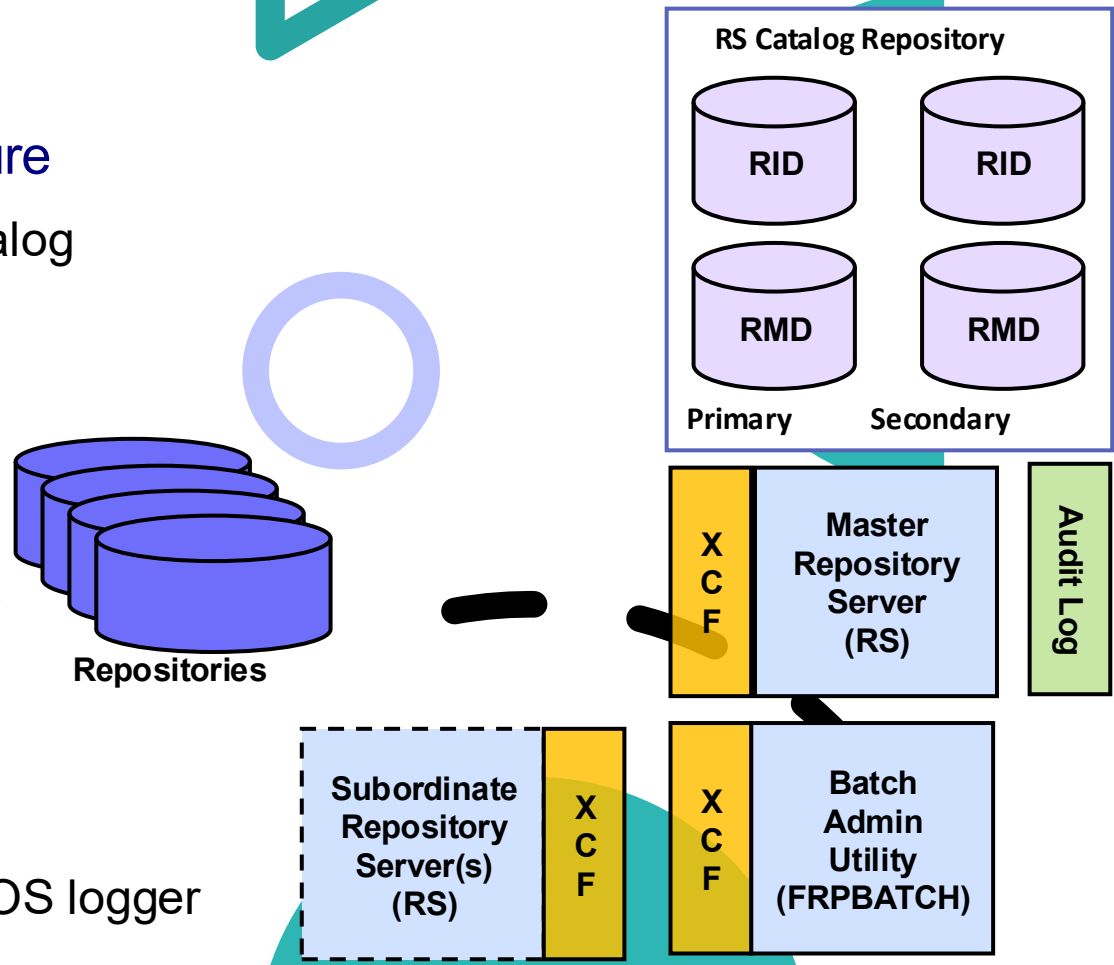

## IMS Repository Function Components: Repository Data Sets

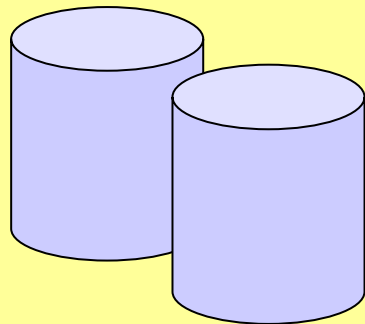

repository index  
data sets  
(primary / secondary)

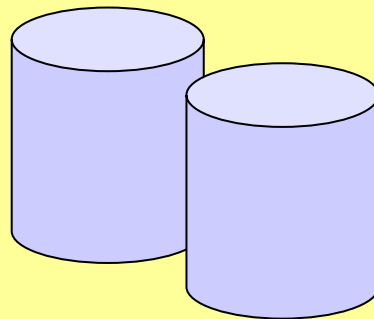

repository member  
data sets  
(primary / secondary)

- Repository data sets
  - Multiple sets of VSAM KSDS data sets
  - Each set composed of
    - Repository index data set
    - Repository member data set
    - Each of these has a primary and secondary data set (duplexed)
      - Optional spare set (third) can be defined
  
- Two types of repository data sets
  - **Catalog repository** data sets
  - **IMS repository** data sets

## IMS Repository Function Components: RS Catalog Data Sets

### RS catalog data sets

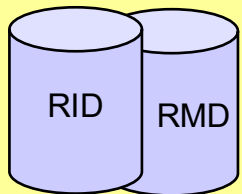

Primary and secondary index data sets

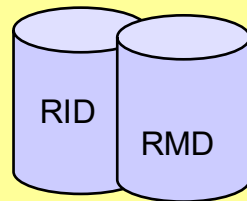

Primary and secondary member

- Catalog repository (RS catalog data sets)
  - Required per repository server
  - Manages the Repository Server (RS) functions
  - Manages information about IMS repository data sets
- Composed of two pairs of data sets
  - Primary index data set and primary member data set (required)
  - Secondary index data set and secondary member data set (required)
- Each pair includes
  - Repository Index Data Set (RID)
    - Stores names and keys of Repository members
  - Repository Member Data Set (RMD)
    - Associates Repository names with Repository data sets

# IMS Repository Function components – IMSRSC Repository

## ■ IMS Resource (IMSRSC) repository

- Contains the stored resource definitions for DRD resources for one or more DRD-enabled IMS systems
  - Resource lists for each IMS
  - Stored resource definitions (programs/transactions/databases/FP routing codes)

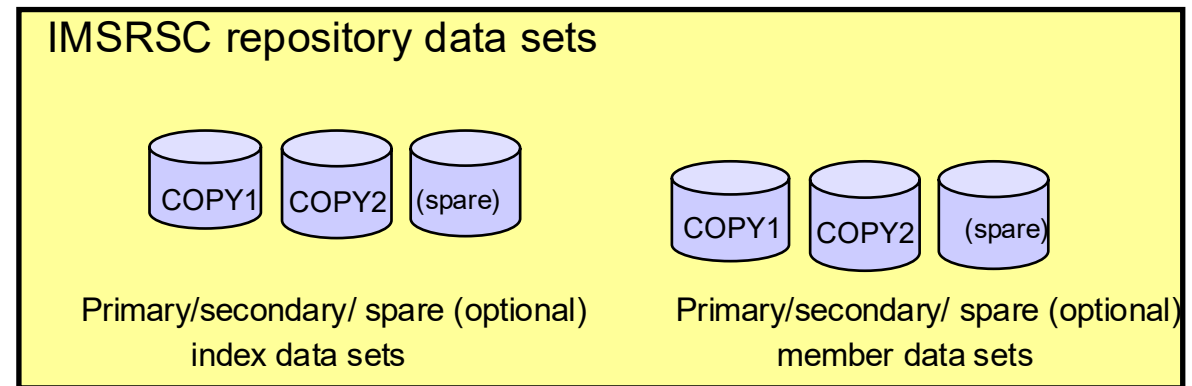

- Composed of up to three pairs of data sets
  - Primary index data set and primary member data set (required) (COPY1)
  - Secondary index data set and secondary member data set (required) (COPY2)
  - Spare index data set and spare member data set (optional and recommended) (SPARE)

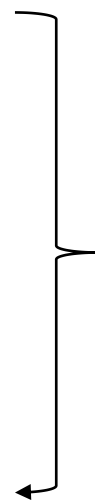

- **States** of these data sets are maintained in RS catalog and can be:
  - Primary (COPY1), Secondary (COPY2), Spare (SPARE), Discarded (DISCARD)
  - Note: IMSRSC repository must have valid primary/secondary sets of data sets or it is stopped

## *IMS Repository Function components – IMSRSC Repository...*

- IMSRSC repository – Why include a Spare pair?
  - Spare recovery capability
    - Works at 'pair' level
    - Empty data sets used on write error on primary or secondary pair
      - Read error attempts read to other good data set
    - Repository server performs recovery automatically if a spare pair is available
    - Valid data set pair (either primary or secondary) is copied to spare pair
    - Failed pair marked 'discarded'
    - IMSRSC repository stopped during this recovery
    - IMSRSC repository restarted with new primary/secondary copies
    - User must define a new pair of empty spare data sets, then use the batch ADMIN utility or repository server commands to set their status to 'spare'

# The Common Service Layer (CSL) Environment & The Repository

- The use of the IMS Repository requires a Common Service Layer (CSL) IMSplex configuration consisting of:
  - Operations Manager (OM)
    - Used for new/modified type-2 commands for repository functions
  - Resource Manager (RM)
    - Used for managing the new Repository Server (RS) address space
    - All online access to Repository Server is through RM address space via XCF Services
    - New type-2 commands for enabling/managing repository server
      - UPDATE RM
      - QUERY RM
    - RM registers to the repository server and connects to the IMSRSC repository(s) during RM initialization
    - RM is enabled to the repository by specifying a Repository Section in the RM initialization member (CSLRlxxx) or via the UPDATE RM command

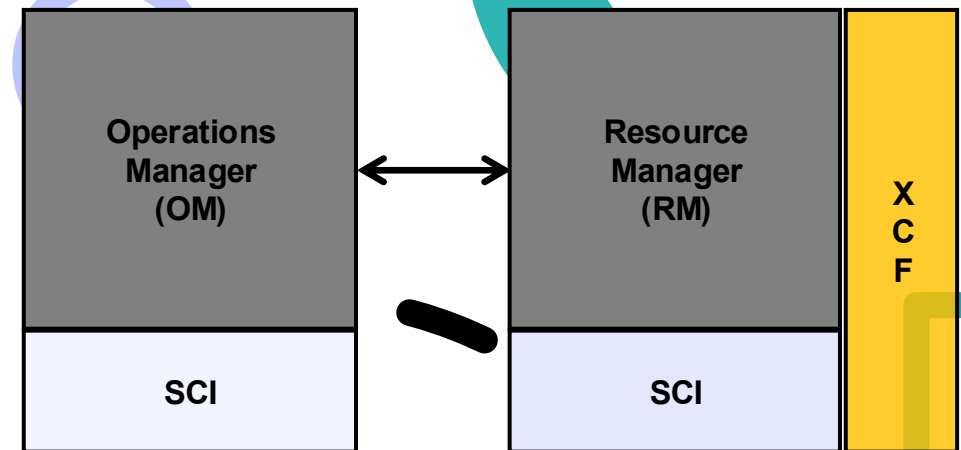

# CSL & The Repository

- A Common Service Layer (CSL) IMSplex configuration consisting of:
  - Structured Call Interface (SCI)
    - Used for communications within the CSL
    - Not used for communications between RM and the RS (uses XCF)
    - RS is not considered a CSL manager
    - Repository server can optionally register with SCI (shows as part of the IMSplex on QUERY IMSPLEX output) though repository server communications are through RM with XCF
  - Optionally, a resource structure in a Coupling Facility
    - Used for repository name and repository type consistency if present
    - Managed by a Common Queue Server (CQS) address space
    - Multiple RMs in an IMSplex require that a resource structure exists
  - SPOC (single point of control) for entering type-2 commands
  - Can be a single-IMS IMSplex or a multiple-IMS IMSplex

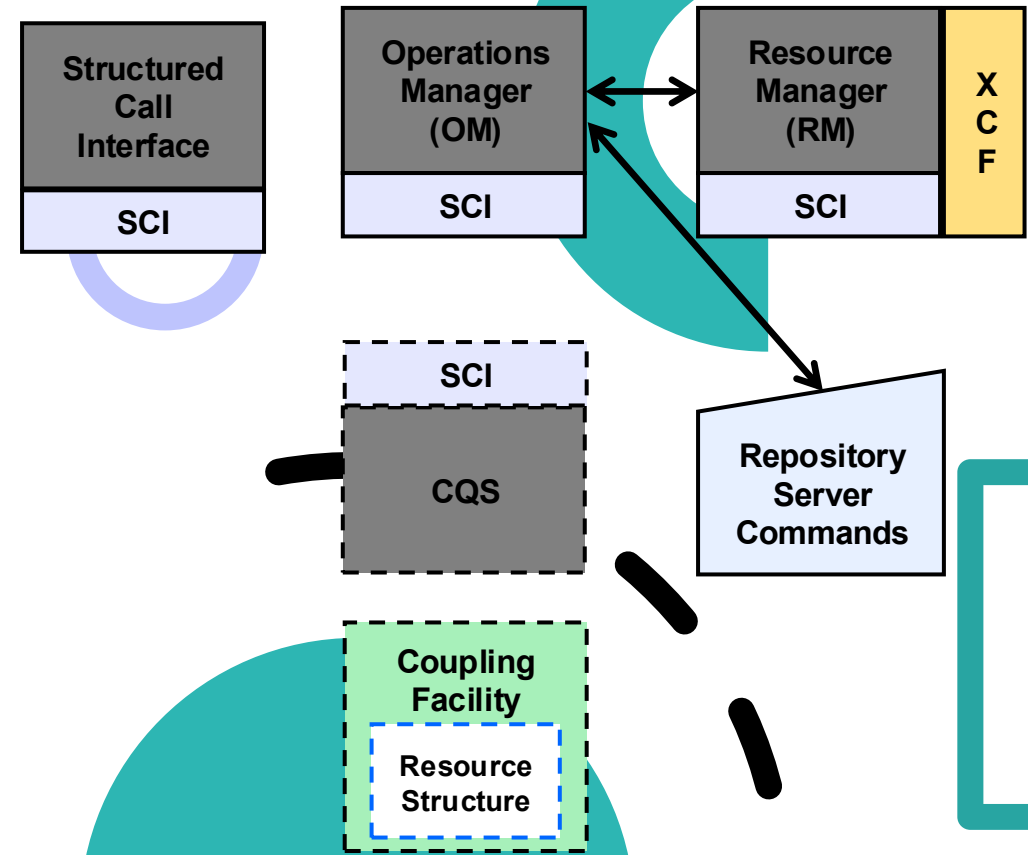

# Security

---

- <https://ibm.biz/BdapaJ>
  - <https://www.ibm.com/docs/en/ims/15.6.0?topic=environments-restricting-access-rs-catalog-repository-imsrsc-repository>
- Basic steps:
  - Set up via SAF profiles for RM access to a particular repository
    - Called 'Connection Security'
  - Set up via SAF profiles for caller access to RM
    - Authorized callers, like IMS
    - Non-authorized callers, like the batch RM utilities
      - 'Member level security' needs to be set up
  - Set up SAF profiles for access to the catalog repository data sets
  - Set up SAF profiles for access to IMSRSC repository
  - Set up SAF profiles for access to members in an IMSRSC repository
  - Set up SAF profiles for who can make changes to the AUDIT level settings
  - Security for batch access via USERID on JOB statement

# IMS Repository Set-up

- <https://www.ibm.com/docs/en/ims/15.6.0?topic=repository-defining-imsrsc>

# My Implementation Steps for the IMS Repository Server

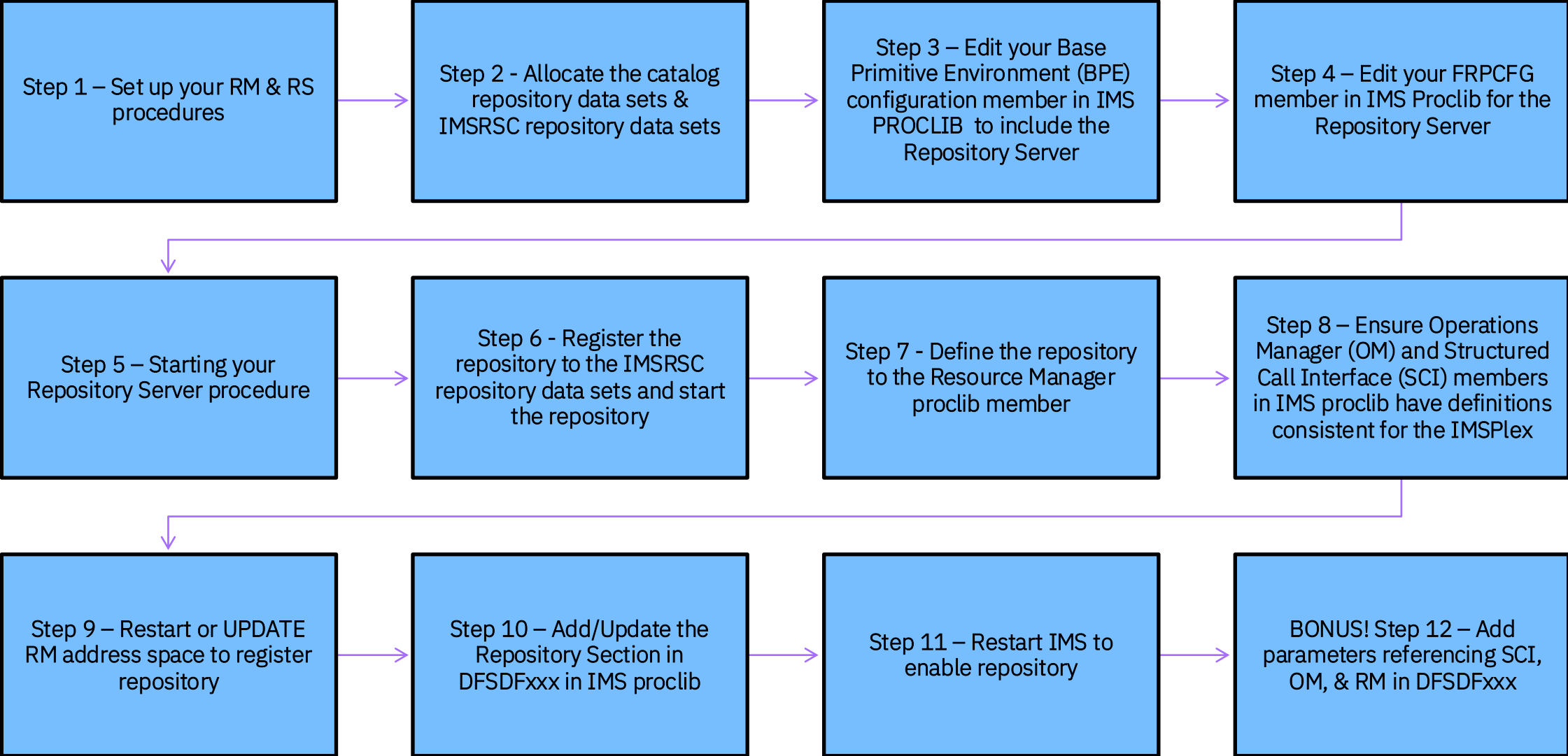

# Step 1 – Set up your RM & RS procedures

Find sample procedures from the IVPs in the IMS INSTALIB data set and copy into the system proclib

- Resource Manager (RM) - IV3U106J
- Repository Server (RS) - IV3U104J

```

EDIT      DFSF10.INSTALIB(IV3U106J) - 01.02      Columns 00001 00072
Command ==>                                     Scroll ==> CSR
000017 /* FUNCTION: START RM
000018 /******
000019 /*
000020 /******@SCPYRT**
000021 /*
000022 /* LICENSED MATERIALS - PROPERTY OF IBM
000023 /*
000024 /* 5635-A06
000025 /*
000026 /* COPYRIGHT IBM CORP. 1989,1998 ALL RIGHTS RESERVED
000027 /*
000028 /* US GOVERNMENT USERS RESTRICTED RIGHTS - USE, DUPLICATION OR
000029 /* DISCLOSURE RESTRICTED BY GSA ADP SCHEDULE CONTRACT WITH
000030 /* IBM CORP.
000031 /*
000032 /******@ECPYRT**
000033 /*-----*
000034 /* RM
000035 /*-----*
000036 /* PARAMETERS:
000037 /* BPECFG - NAME OF BPE MEMBER
000038 /* RMINIT - SUFFIX FOR YOUR CSLRXXX MEMBER
000039 /* ARMRST - INDICATES IF ARM SHOULD BE USED
000040 /* RMNAME - NAME OF THE RM BEING STARTED
000041 /*-----*
000042 /*
000043 /*IEFPROC EXEC PGM=BPEINI00,REGION=3000K,
000044 /* PARM=( "BPECFG=BPECFG", "BPEINIT=CSLRINI0", "RMINIT=RRM")
000045 /* "ARMRST=N", "RMNAME=RM1")
000046 /*
000047 /*STEPLIB DD DSN=DFSF10.SDFSRESL,DISP=SHR
000048 /*
000049 /*PROCLIB DD DSN=DFSF10.PROCLIB,DISP=SHR
000050 /*
000051 /*SYSPRINT DD SYSOUT=*
000052 /*SYSUDUMP DD SYSOUT=*
000053 /*
***** Bottom of Data *****

```

```

EDIT      DFSF10.INSTALIB(IV3U104J) - 01.01      Columns 00001 00072
Command ==>                                     Scroll ==> CSR
000016 /* FUNCTION: Start the Repository Server
000017 /******
000018 /*
000019 /******@SCPYRT**
000020 /*
000021 /* LICENSED MATERIALS - PROPERTY OF IBM
000022 /*
000023 /* 5635-A06
000024 /*
000025 /* COPYRIGHT IBM CORP. 1989,1998 ALL RIGHTS RESERVED
000026 /*
000027 /* US GOVERNMENT USERS RESTRICTED RIGHTS - USE, DUPLICATION OR
000028 /* DISCLOSURE RESTRICTED BY GSA ADP SCHEDULE CONTRACT WITH
000029 /* IBM CORP.
000030 /*
000031 /******@ECPYRT**
000032 /*
000033 /*
000034 /*RSRVNMRP PROC RGN=512M,BPERCFG=BPERECFN,
000035 /* FPQRCFG=RSCFIGNM,SOUT="*"
000036 /*
000037 /*RESPPROC EXEC PGM=BPEINI00,REGION=&RGN,
000038 /* PARM="BPEINIT=FRPINI00,BPECFG=&BPERCFG,FRPCFG=&FPQRCFG"
000039 /*
000040 /*STEPLIB DD DSN=DFSF10.SDFSRESL,DISP=SHR
000041 /*
000042 /*PROCLIB DD DSN=DFSF10.PROCLIB,DISP=SHR
000043 /*
000044 /*FRPPRINT DD SYSOUT=&SOUT
000045 /*SYSPRINT DD SYSOUT=*
000046 /*SYSUDUMP DD SYSOUT=*
000047 /* PEND
000048 /*
000049 /*REPOSVER EXEC RSRVNMRP
000050 /*
***** Bottom of Data *****

```

# Step 1 (cont.) – Set up your RM & RS procedures

Adjusted the system steplib & proclib concatenations for my environment  
Referenced the IMS proclib definitions for the Repository Server and Resource Manager

```
EDIT      VENDOR.PROCLIB(IMS15RM1) - 01.00      Columns 00001 00072
Command ==>      Scroll ==> CSR
000031 /*
000032 //IEFPROC EXEC PGM=BPEINI00,REGION=3000K,
000033 // PARM=('BPECFG=BPECONFG','BPEINIT=CSLRINI0','RMINIT=000',
000034 //      'ARMRST=N','RMNAME=RM1')
000035 /*
000036 //STEPLIB DD DSN=DFSF10.USER.SDFSRESL,DISP=SHR
000037 //      DD DSN=DFSF10.SDFSRESL,DISP=SHR
000038 //PROCLIB DD DSN=VENDOR.PROCLIB,DISP=SHR
000039 //      DD DSN=SVTSC.PROCLIB,DISP=SHR
000040 //      DD DSN=DFSF10.PROCLIB,DISP=SHR
000041 /*
000042 //SYSPRINT DD SYSOUT=*
000043 //SYSUDUMP DD SYSOUT=*
000044 /*
***** ***** Bottom of Data *****
```

```
EDIT      VENDOR.PROCLIB(IMS15RS1) - 01.00      Columns 00001 00072
Command ==>      Scroll ==> CSR
002300 /*
002400 //RSRVNMR PROC RGN=512M,BPERCFG=BPERECFN,
002500 //      FPQRCFG=RSCFIGNM,SOUT='*'
002600 /*
002700 //RESPPROC EXEC PGM=BPEINI00,REGION=&RGN,
002800 // PARM='BPEINIT=FRPINI00,BPECFG=&BPERCFG,FRPCFG=&FPQRCFG'
002900 /*
003000 //STEPLIB DD DSN=DFSF10.USER.SDFSRESL,DISP=SHR
003100 //      DD DSN=DFSF10.SDFSRESL,DISP=SHR
003200 /*
003300 //PROCLIB DD DSN=VENDOR.PROCLIB,DISP=SHR
003400 //      DD DSN=SVTSC.PROCLIB,DISP=SHR
003500 //      DD DSN=DFSF10.PROCLIB,DISP=SHR
003600 /*
003700 //FRPPRINT DD SYSOUT=&SOUT
003800 //SYSPRINT DD SYSOUT=*
003900 //SYSUDUMP DD SYSOUT=*
004000 /*
004100 /**REPOSER EXEC RSRVNMRP
004200 /*
```

# Step 2 - Allocate the RS catalog repository data sets & IMSRSC repository data sets

Find sample JCL member, IV3U101J, from the IVPs in the IMS INSTALIB data set

- The job creates two sets of each plus a spare – KSDS data sets

```
EDIT      DFSF10.INSTALIB(IV3U101J) - 01.01      Columns 00001 00072
Command ==> █                                     Scroll ==> CSR
000030 /*
000031 /* SCRATCH DATA SETS
000032 /*
000033 /*SCRATCH EXEC PGM=IDCAMS,DYNAMNBR=200
000034 //SYSPRINT DD SYSOUT=*
000035 //SYSIN DD *
000036 DELETE DFSF10.REPO.CATPRI.RID CLUSTER
000037 DELETE DFSF10.REPO.CATPRI.RMD CLUSTER
000038 DELETE DFSF10.REPO.CATSEC.RID CLUSTER
000039 DELETE DFSF10.REPO.CATSEC.RMD CLUSTER
000040 DELETE DFSF10.REPO.IMSPRI.RID CLUSTER
000041 DELETE DFSF10.REPO.IMSPRI.RMD CLUSTER
000042 DELETE DFSF10.REPO.IMSSEC.RID CLUSTER
000043 DELETE DFSF10.REPO.IMSSEC.RMD CLUSTER
000044 DELETE DFSF10.REPO.IMSSPR.RID CLUSTER
000045 DELETE DFSF10.REPO.IMSSPR.RMD CLUSTER
000046 DELETE DFSF10.MODBLKSA.RDDS
000047 SET MAXCC=0
000048 /*
000049 /*
000050 /* ALLOCATE DATA SETS
000051 /*
000052 //ALLOCATE EXEC PGM=IDCAMS,DYNAMNBR=200
000053 //SYSPRINT DD SYSOUT=*
000054 //SYSIN DD *
000055 DEFINE CLUSTER(
000056     NAME(DFSF10.REPO.CATPRI.RID) -
000057     REUSE
000058     INDEXED
000059     KEYS(128,0)
000060     FREESPACE(10 10)
000061     RECORDSIZE(282 282)
000062     SHAREOPTIONS(2 3)
000063     CONTROLINTERVALSIZE(8192)
000064     VOLUMES(VPDFSB)
000065     CYLINDERS(1 1)
000066 )
000067 DATA(
```

```
EDIT      DFSF10.INSTALIB(IV3U101J) - 01.01      Columns 00001 00072
Command ==> █                                     Scroll ==> CSR
000196     INDEX(
000197         NAME(DFSF10.REPO.IMSSEC.RMD.I) -
000198     )
000199 DEFINE CLUSTER(
000200     NAME(DFSF10.REPO.IMSSPR.RID) -
000201     REUSE
000202     INDEXED
000203     KEYS(128,0)
000204     FREESPACE(10 10)
000205     RECORDSIZE(282 282)
000206     SHAREOPTIONS(2 3)
000207     CONTROLINTERVALSIZE(8192)
000208     VOLUMES(VPDFSB)
000209     CYLINDERS(1 1)
000210 )
000211 DATA(
000212     NAME(DFSF10.REPO.IMSSPR.RID.D) -
000213 )
000214 INDEX(
000215     NAME(DFSF10.REPO.IMSSPR.RID.I) -
000216 )
000217 DEFINE CLUSTER(
000218     NAME(DFSF10.REPO.IMSSPR.RMD) -
000219     REUSE
000220     INDEXED
000221     KEYS(12,0)
000222     FREESPACE(20 20)
000223     RECORDSIZE(8185 8185)
000224     SHAREOPTIONS(2 3)
000225     CONTROLINTERVALSIZE(8192)
000226     VOLUMES(VPDFSB)
000227     CYLINDERS(1 1)
000228 )
000229 DATA(
000230     NAME(DFSF10.REPO.IMSSPR.RMD.D) -
000231 )
000232 INDEX(
000233     NAME(DFSF10.REPO.IMSSPR.RMD.I) -
000234 )
```

## Step 3 – Edit your Base Primitive Environment (BPE) configuration member in IMS PROCLIB to include the Repository Server

Tracing definitions for capturing internal events within the Repository Server

Take the defaults as shown or adjust as necessary for your environment's requirements

```
EDIT      DFSF10.PROCLIB(BPERECFN) - 01.00          Columns 00001 00072
Command ==>                                Scroll ==> CSR
***** ***** Top of Data *****
000001 # DEFINITIONS FOR REPO TRACES
000002 TRCLEV=(*,HIGH REPO,PAGES=300)/* DEFAULT ALL TRACES TO HIGH */
***** ***** Bottom of Data *****
```

# Step 4 – Edit your FRPCFG member in IMS Proclib for the Repository Server

- Defines RS configuration parameters for performance, communications, and security
- Also identifies the names of the catalog repository data sets to be used
- Always keep in mind the RSNAM, IMSPLEX, XCF Group Name definitions

```
EDIT          DFSF10.PROCLIB (RSCFIGNM) - 01.00
Command ==> 
***** ***** Top of Data ****
000001 XCF_THREADS=8
000002 MAX_COMMUNICATION_RETRY=32
000003 MBR_CORE_MAX=1024
000004 IMSPLEX(NAME=PLEX1)
000005 RSNAM=RSRVNM
000006 PRIMARY_CATALOG_REPOSITORY_INDEX=(
000007 DFSF10.REPO.CATPRI.RID)
000008 PRIMARY_CATALOG_REPOSITORY_MEMBER=(
000009 DFSF10.REPO.CATPRI.RMD)
000010 SECONDARY_CATALOG_REPOSITORY_INDEX=(
000011 DFSF10.REPO.CATSEC.RID)
000012 SECONDARY_CATALOG_REPOSITORY_MEMBER=(
000013 DFSF10.REPO.CATSEC.RMD)
000014 VSAM_BUFNO=256
000015 VSAM_BUFSIZE=8
000016 XCF_GROUP_NAME=REPXCFGN
000017 AUDIT=NO
000018 AUDIT_FAIL=CONTINUE
000019 AUDIT_LEVEL=HIGH
000020 AUDIT_DEFAULT=NOAUDIT
***** ***** Bottom of Data ****
```

# Step 5 – Starting your Repository Server procedure

```
STC01183 ---- WEDNESDAY, 06 NOV 2024 ----
STC01183 IEF695I START IMS15RS1 WITH JOBNAME IMS15RS1 IS ASSIGNED TO USER STCOP
STC01183 $HASP373 IMS15RS1 STARTED
STC01183 FRP2006I - Server starting: Release 1.2.0, XCF group REPXCFGN RSRVNM RP
STC01183 FRP2012I - Opening repository: CATALOG
STC01183 FRP2016I - Repository opened: CATALOG
STC01183 FRP2002I - Master repository server status obtained RSRVNM RP
STC01183 FRP2025I - Server start completed RSRVNM RP
STC01183 FRP2026I - XCF group REPXCFGN joined successfully RSRVNM RP
STC01183 FRP2012I - Opening repository: RSRVNM
STC01183 IEC161I 152-061,IMS15RS1,IMS15RS1,SYS00009,,DFSF10.REPO.IMSSPR.RID,
IEC161I DFSF10.REPO.IMSSPR.RID.D,CATALOG.DFSF10
STC01183 IEC161I 152-061,IMS15RS1,IMS15RS1,SYS00010,,DFSF10.REPO.IMSSPR.RMD,
IEC161I DFSF10.REPO.IMSSPR.RMD.D,CATALOG.DFSF10
STC01183 FRP2016I - Repository opened: RSRVNM
```

/S IMS15RS1 to start the  
RS address space

```
IEC161I 152-061,IMS15RS1,IMS15RS1,SYS00009,,DFSF10.REPO.IMSSPR.RID,
IEC161I DFSF10.REPO.IMSSPR.RID.D,CATALOG.DFSF10
IEF237I 1A54 ALLOCATED TO SYS00010
IEC161I 152-061,IMS15RS1,IMS15RS1,SYS00010,,DFSF10.REPO.IMSSPR.RMD,
IEC161I DFSF10.REPO.IMSSPR.RMD.D,CATALOG.DFSF10
FRP2016I - Repository opened: RSRVNM                                RSRV
The following configuration parameters are in effect:
  Number of XCF message threads (XCF_THREADS)                      8
  XCF group name (XCF_GROUP_NAME)                                  REPXCFGN
  Max storage before allocating data space (MBR_CORE_MAX)          1024K
  SAF security class name (SAF_CLASS)
  Number of VSAM buffers to use VSAM I/O (VSAM_BUFNO)              256
  VSAM buffer size (VSAM_BUFSIZE)                                  8K
  Server-busy max retry attempts (MAX_COMMUNICATION_RETRY)         32
  Catalog primary RID data set name                                DFSF10.REPO.CATPRI.
  Catalog primary RMD data set name                                DFSF10.REPO.CATPRI.
  Catalog secondary RID data set name                              DFSF10.REPO.CATSEC.
  Catalog secondary RMD data set name                              DFSF10.REPO.CATSEC.
  Audit enabled? (AUDIT)                                          NO
***** BOTTOM OF DATA *****
```

# Step 6 - Register the repository to the IMSRSC repository data sets and start the repository

- ADD and START FRPBATCH commands
- Manually send commands to the repository
- Submit JCL job – Sample batch job found in IVP dataset, IV3U105J

```
EDIT      DFSF10.INSTALIB(IV3U105J) - 01.01      Columns 00001 00072
Command ==>                                     Scroll ==> CSR
000033  /*
000034  //REPOADD EXEC PGM=FRPBATCH,PARM='XCFGROUP=REPXCFGN'
000035  //STEPLIB DD DISP=SHR,DSN=DFSF10.SDFSRESL
000036  //SYSPRINT DD SYSOUT=*
000037  //SYSIN DD *
000038  ADD REPOSITORY(IMSREPNM) +
000039  REPDSN1RID(DFSF10.REPO.IMPRI.RID) +
000040  REPDSN1RMD(DFSF10.REPO.IMPRI.RMD) +
000041  REPDSN2RID(DFSF10.REPO.IMSSEC.RID) +
000042  REPDSN2RMD(DFSF10.REPO.IMSSEC.RMD) +
000043  REPDSN3RID(DFSF10.REPO.IMSSPR.RID) +
000044  REPDSN3RMD(DFSF10.REPO.IMSSPR.RMD) +
000045  AUTOOPEN(YES)
000046  START REPOSITORY(IMSREPNM)
000047  /*
***** ***** Bottom of Data *****
```

RSNAME definition goes here

# Step 7 - Define the repository to the Resource Manager proclib member

```
EDIT          DFSF10.PROCLIB(CSLRI000) - 01.00          Columns 00001 00072
Command ==>                                Scroll ==> CSR
***** Top of Data *****
000001 *-----*
000002 * RM INITIALIZATION PROCLIB MEMBER.                *
000003 *-----*
000004 ARMRST=N, /* SHOULD ARM RESTART RM ON FAILURE */
000005 RMNAME=RM1, /* RM NAME (RMID = RM1RM) */
000006 IMSPLEX(NAME=PLEX1) /* IMSPLEX NAME (CSLPLEX1) */
000007 *-----*
000008 * REPOSITORY SECTION ADDED 10/02/24                *
000009 *-----*
000010 <SECTION=REPOSITORY>
000011 * REPOSITORY=(NAME=RSRVNMRP,TYPE=IMSRSC,GROUP=REPXCFGN)
000012 REPOSITORY=(NAME=RSRVNM,TYPE=IMSRSC,GROUP=REPXCFGN)
000013 * AUDITACCESS=NOAUDIT | SECURITY | UPDATE | READ | SYSTEMREAD
000014 *-----*
000015 * END OF MEMBER CSLRI000                            *
000016 *-----*
***** Bottom of Data *****
```

# Step 8 – Ensure Operations Manager (OM) and Structured Call Interface (SCI) members in IMS proclib has definitions consistent for the IMSplex

```
EDIT DFSF10.PROCLIB(CSLOI000) - 01.00 Columns 00001 00072
Command ==> Scroll ==> CSR
***** ***** Top of Data *****
000001 *-----*
000002 * OM INITIALIZATION PROCLIB MEMBER - CSLOI000 *
000003 *-----*
000004 ARMST=N, /* SHOULD ARM RESTART OM ON FAILURE */
000005 CMDLANG=ENU, /* USE ENGLISH FOR COMMAND DESC */
000006 CMDSEC=N, /* NO COMMAND SECURITY */
000007 OMNAME=OM1, /* OM NAME (OMID = OM1OM) */
000008 IMSPLEX(
000009 NAME=PLEX1, /* IMSPLEX NAME (CSLPLEX1) */
000010 AUDITLOG=SYSLOG.OM2Q01.LOG), /* MVS LOG STREAM */
000011 CMDTEXTDSN=DFSF10.SDFSDATA /* CMD TEXT DATASET */
000012 *-----*
000013 * END OF MEMBER CSLOI000
000014 *-----*
```

```
EDIT DFSF10.PROCLIB(CSLSI000) - 01.00 Columns 00001 00072
Command ==> Scroll ==> CSR
***** ***** Top of Data *****
000001 *-----*
000002 * SCI INITIALIZATION PROCLIB MEMBER. *
000003 *-----*
000004 ARMST=N, /* SHOULD ARM RESTART SCI ON FAILURE */
000005 SCINAME=SCI1, /* SCI NAME (SCIID = SCI1SCI) */
000006 IMSPLEX(NAME=PLEX1) /* IMSPLEX NAME (CSLPLEX1) */
000007 *-----*
000008 * END OF MEMBER CSLSI000
000009 *-----*
***** ***** Bottom of Data *****
```

## Step 9 – Restart or UPDATE RM address space to register repository

Submit Type-2 Command: `UPDATE RMTYPE(REPO) REPOTYPE(IMSRSC)`

Manual PURGE and START of the Resource Manager address space in SDSF

Either option will pick up the new Repository Server definitions

Look for the message `*CSL2502A RM WAITING FOR MASTER REPOSITORY SERVER...` to confirm that the Repository Server is registered

```
0090 *CSL2502A RM WAITING FOR MASTER REPOSITORY SERVER ADDRESS SPACE RM1RM
```

# Step 10 – Add/Update the Repository Section in DFSDFxxx in IMS proclib

```
EDIT          DFSF10.PROCLIB(DFSDF000) - 01.09          Columns 00001 00072
Command ==>           Scroll ==> CSR
***** ***** Top of Data *****
000001 *-----*
000002 * REPOSITORY SECTION - ADDED 10/01/24 *
000003 *-----*
000004 <SECTION=REPOSITORY>
000005 REPOSITORY=(TYPE=(IMSRSC))
000006 *-----*
```

# Step 11 – Restart IMS to enable repository

New startup process:

IRLM Region → /S IMS15RL1

RS Address Space → /S IMS15RS1

Control Region → /S IMS15CR1

SCI address space → IMS15SCI

OM Address Space → /S IMS15OM1

RM Address Space → /S IMS15RM1

Control Region with a COLD START → /S IMS15CR1... /R ##,/NRE CHKPT 0 FORMAT ALL

Note: IMS READY prompt from WTO will appear after RS initialization is complete.

New Shutdown:

Checkpoint → /R ##,/CHE SNAPQ

Terminate Control Region → /R ##,/CHE FREEZE

RS Address Space → /P IMS15RS1

RM Address Space → /P IMS15RM1

OM Address Space → /P IMS15OM1

SCI Address space → /P IMS15SCI

IRLM Region → /P IMS15RL1

# BONUS! Step 12 – Add parameters referencing SCI, OM, & RM in DFSDFxxx

Automatically starting Common Service Layer address spaces

This won't start Repository Server procedure but brings out the 3 address spaces required when the Control Region is initiated

The Repository Server should be the address space that comes up after RM has initiated

To bring down the CSL address spaces during shutdown, manually purge each region OR issue one of the two following commands :

- /F scijobname,SHUTDOWN CSLLCL
- /F scijobname,SHUTDOWN CSLPLEX

```
*-----*
* COMMON SERVICE LAYER SECTION                               *
*-----*
<SECTION=COMMON_SERVICE_LAYER>
CMDSEC=N                /* NO CMD AUTHORIZATION CHECKING */
IMSPLEX=PLEX1           /* IMSPLEX NAME                   */
MODBLKS=DYN             /* DRD ENABLED:MODBLKS OLC DISABLE */
OMPROC=IMS150M1         /* OPERATIONS MANAGER            */
RMENV=Y                 /* RESOURCE MANAGER ENABLED      */
RMPROC=IMS15RM1         /* RESOURCE MANAGER PROC         */
SCIPROC=IMS15SCI        /* SERVICE CALL INTERFACE        */
*-----*
```

# Step 12 (cont.) – Restart IMS to enable automatic startup of CSL

New startup process:

IRLM Region → /S IMS15RL1

RS Address Space → /S IMS15RS1

Control Region → /S IMS15CR1

(SCI, OM, & RM address spaces will initialize in succession automatically)

COLD START → /R ##,/NRE CHKPT 0 FORMAT ALL

Note: IMS READY prompt from WTO will appear after RS initialization is complete.

New Shutdown:

Checkpoint → /R ##,/CHE SNAPQ

Terminate Control Region → /R ##,/CHE FREEZE

CSL Termination → /F IMS15SCI,SHUTDOWN CSLLCL or CSLPLEX

(SCI, OM, & RM address spaces will terminate in succession automatically)

RS Address Space → /P IMS15RS1

IRLM Region → /P IMS15RL1

# IMS Repository Value

# Experience this in action through TSO SPOC!

EXEC 'imshlq.SDFSEXEC(DFSAPPL)' 'HLQ(imshlq)'

```

PLEX1                               IMS Single Point of Control
Command ==> █

-----
Plex . . PLEX1  Route . . IVP1      Wait . .
Response for: QUERY TRAN NAME(IVTNO) SHOW(ALL)          More: >
Trancode MbrName  CC LPSBname LCls  LQCnt  LLCT  LPLCT  LPLCTTime  LCPRI  LNPRI
IVTNO    IVP1    0 DFSIYP1  1      0  65535  65535    6553500    1     1
    
```

```

PLEX1                               IMS Single Point of Control
Command ==> █

-----
Plex . . PLEX1  Route . . IVP1      Wait . .
Response for: QUERY TRAN NAME(IVTNXX) SHOW(ALL)         More: >
Trancode MbrName  CC CCText          LPSBname LCls  LQCnt  LLCT  LPLCT  LPL
IVTNXX   IVP1    10 NO RESOURCES FOUND
    
```

QUERY existing and nonexistent resources like transactions

# Experience this in action though TSO SPOC!

```
IMS Single Point of Control
Command ==>
-----
Plex . . PLEX1 Route . . IVP1 Wait . .
Response for: CREATE TRAN NAME(IVTNXX) SET(PGM(DFSIVP1) CLASS(...
Trancode MbrName CC
IVTNXX IVP1 0
```

```
IMS Single Point of Control
Command ==>
-----
Plex . . PLEX1 Route . . IVP1 Wait . .
Response for: QUERY TRAN NAME(IVTNXX) SHOW(ALL) More: >
Trancode MbrName CC LPSBname LCls LQCnt LLCT LPLCT LPLCTTime LCPRI LNPRI
IVTNXX IVP1 0 DFSIVP1 3 0 65535 65535 6553500 1 1
```

CREATE a new transaction, and then QUERY it to see it already registered!

# Usage

With DRD –resource definition changes can be made to a running system and rebuilt across all restarts

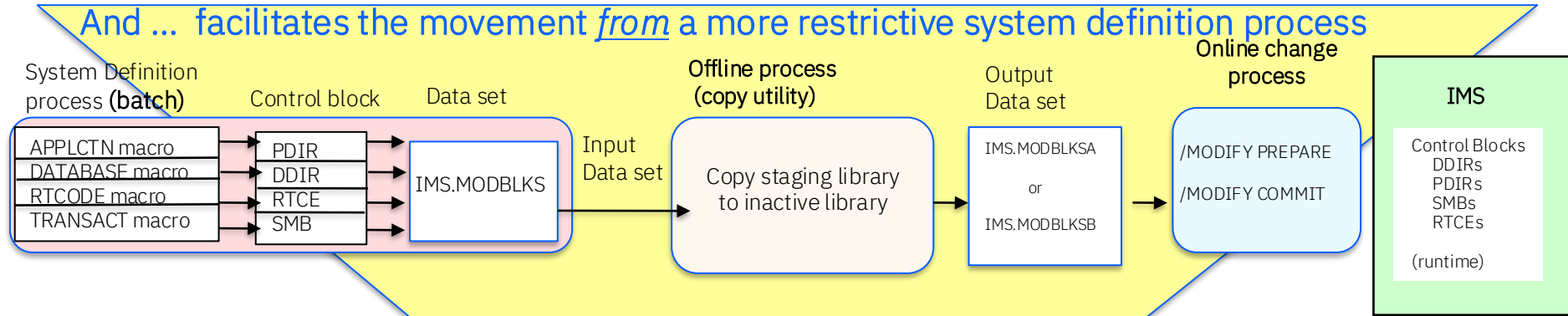

- **To Dynamic Resource Definition – DRD (for modblks resources)**

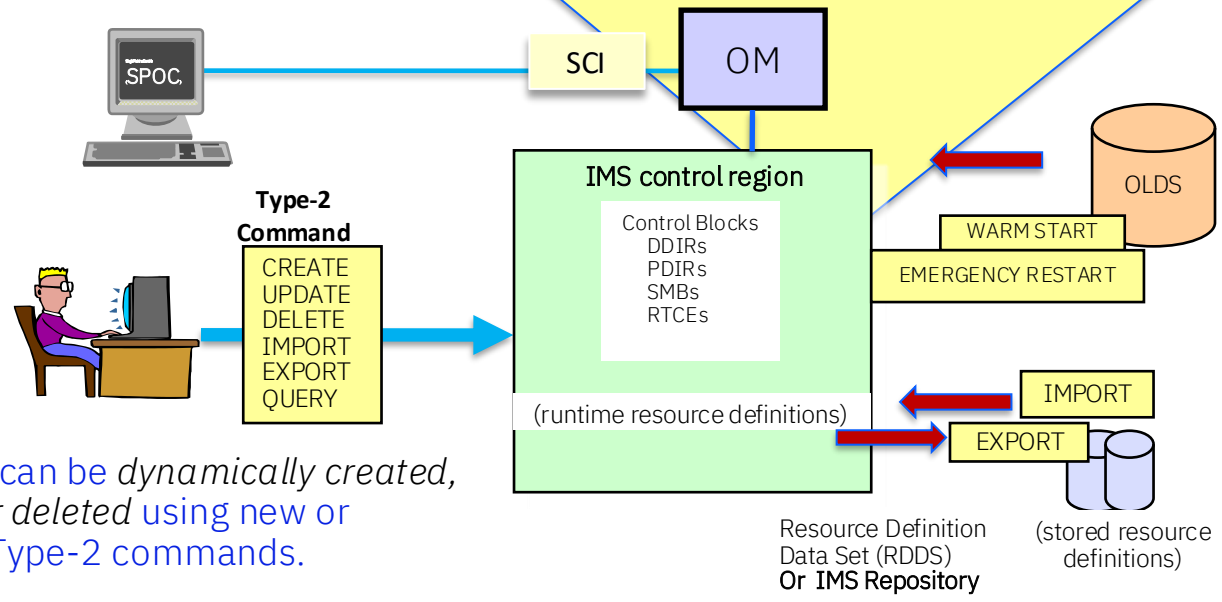

Definitions are logged when created, updated, or deleted, and at system checkpoint time and recovered from the logs during warm and emergency restart

During IMS cold start processing, resource definitions may be IMPORTED from RDDS/Repository

Definitions can be EXPORTED to the IMS Repository during simple or shutdown checkpoints or by command

Definitions can be dynamically created, updated, or deleted using new or enhanced Type-2 commands.

## ***Value of the IMS Repository for DRD***

- Full support for populating, managing, storing, sharing, and retrieving a consistent set of DRD stored resource definitions for multiple-IMS IMSplexes and single-IMS IMSplexes in a single place
- Provides improved availability
  - Repository can be enabled/disabled without an IMS outage via command
  - Duplexing of data plus spare capability improves data availability
- Provides single source consistency for DRD stored resource definitions
  - No need for multiple sets of RDDSs in a multiple-IMS IMSplex
  - No need for coordinating multiple sets of RDDSs in a multiple-IMS IMSplex
  - Repository architecture controls consistency and integrity of data

**A strategic IMS architectural direction  
Based upon BPE, CSL, IMSplex architecture**

Questions?  
Comments?

Thank you!